

MODEL AM8a
PCM/VF CALL ANALYZER
INSTRUCTION MANUAL

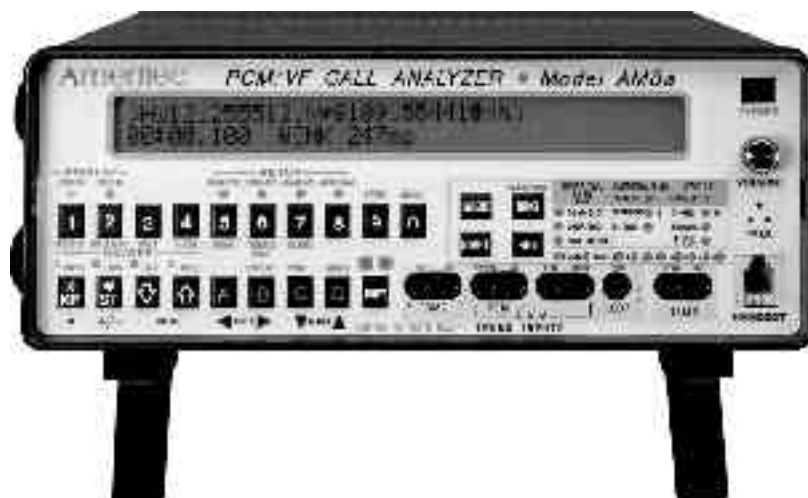

Model AM8a
PCM/VF CALL ANALYZER
INSTRUCTION MANUAL

February 10, 2000

Technical Data Subject to
Change without Notice

Ameritec

760 Arrow Grand Circle
Covina, CA 91722 USA
TEL 626.915.5441
FAX 626.915.7181
www.ameritec.com

For extra copies of this
manual, order Part
No. 18-0037

© 2000 Ameritec Corporation

When using the padded carrying case for the AM8a (P/N 87-0070C), **DO NOT PLACE** the power cord around the side of the AM8a in the manner demonstrated in Figure 1.

Instead, be certain to **WIND THE CORD UNDER THE CASING** in the area between the feet, as shown in Figure 2.

Failure to follow this procedure could cause deterioration of the cord and increase the possibility of electric shock.

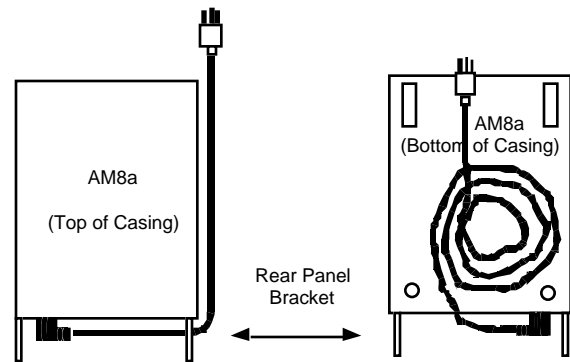

Figure 1 — WRONG

Figure 2 — CORRECT

Record of Revisions

	December 1991	Original Issue.
	February 1992	General data revision.
	August 1992	Software upgrade. General format change and reprint.
	January 1993	General data revision.
	May 1993	Changed listing fonts. Reformatted. Corrected RX connections.
	March 1994	General corrections and additions. Added Test Procedure Guide.
	October 1994	Logo change. Test Procedure Guide removed.
	May 1995	Added Warranty, Calibration, and Repair info.
	August 1996	Added E-Mail Address to logos.
K	December 2, 1999	Changed GUARDms value for DTMF/MF ANALYZE 3.
L	February 10, 2000	Reformatted entire manual and added MF(R1) note.

Table of Contents

1. FRONT PANEL OPERATION	1-1
1.1 FRONT PANEL PROGRAMMING METHODS.....	1-1
1.1.1 SHIFT Key.....	1-1
1.1.2 Arrow Keys.....	1-2
1.2 EVENTS AND METER KEYS AND DISPLAY.....	1-3
1.2.1 EVENTS ([SHIFT][1]) Key.....	1-3
1.2.2 Events Display Character Set.....	1-4
1.2.3 Dialed Digits.....	1-7
1.2.4 METER ([SHIFT][2]) Key.....	1-7
1.3 SETUP AREA.....	1-8
1.3.1 CONFIG'N ([SHIFT][5]) Key.....	1-8
1.3.2 EMULATE ([SHIFT][6]) Key.....	1-8
1.3.3 ANALYZE ([SHIFT][7]) Key.....	1-8
1.3.4 AUTO DIAL ([SHIFT][8]) Key.....	1-8
1.4 CONTROL ON/OFF KEYS.....	1-9
1.4.1 INPUT ([SHIFT][*, KP]) Key.....	1-9
1.4.2 TMS ([SHIFT][#, ST]) Key.....	1-9
1.4.3 TALK ([SHIFT][ VALUE]) Key.....	1-10
1.4.4 AUTO ([SHIFT][ VALUE]) Key.....	1-10
1.5 MENU/DATA CONTROL KEYS.....	1-10
1.5.1 FREEZE ([SHIFT][B]) Key.....	1-10
1.5.2 PRINT ([SHIFT][C]) Key.....	1-11
1.5.3 CANCEL ([SHIFT][D]) Key.....	1-11
1.6 SIGNALING KEYS.....	1-11
1.6.1 SEIZE Key.....	1-11
1.6.2 START Key.....	1-12
1.6.3 RING Key.....	1-12
1.6.4 REV Key.....	1-12
1.6.5 SEND TONE ([SHIFT][RING]) Key.....	1-12

1.7 DATA ENTRY KEYS FOR SIGNALING.....	1-13
1.7.1 WAIT DT ([SHIFT][SHIFT][1] Key.....	1-13
1.7.2 WAIT WINK ([SHIFT][SHIFT][2] Key.....	1-13
1.7.3 WAIT ([SHIFT][SHIFT][3] Key.....	1-13
1.7.4 FLASH ([SHIFT][SHIFT][4] Key.....	1-13
1.7.5 UNBALANCE ([SHIFT][SHIFT][5] Key.....	1-13
1.7.6 TOGGLE DIAL ([SHIFT][SHIFT][6] Key.....	1-13
1.7.7 BLANK ([SHIFT][SHIFT][7] Key.....	1-13
1.8 SIGNALING STATUS LEDs.....	1-14
1.9 STORE SETUP.....	1-15
1.10 RECALL SETUPS.....	1-16
1.10.1 RECALL Setup Parameters.....	1-16
1.10.2 RECALL Auto Dial Sequence.....	1-16
1.11 SPEAKERPHONE/AUDIO MONITOR.....	1-16
1.11.1 Speakerphone in talk mode.....	1-16
1.11.2 Handset.....	1-17
1.11.3 Audio Monitoring.....	1-17
2. CONFIGURATION PARAMETERS.....	2-1
2.1 MODE CONFIG.....	2-1
2.1.1 IMITATE.....	2-1
2.1.2 MODE.....	2-1
2.2 CIRCUIT CONFIG.....	2-2
2.2.1 ANALOG IMPEDANCE.....	2-2
2.2.2 ANALOG/PCM.....	2-2
2.3 PCM CONFIG 1 and PCM CONFIG 2.....	2-3
2.3.1 INPUT.....	2-3
2.3.2 FRAMING.....	2-4
2.3.3 ZERO SUP.....	2-4
2.3.4 CHAN.....	2-5
2.3.5 OFF HK a/b or ON HK a/b.....	2-5

2.4 TRUNK CONFIG	2-5
2.4.1 TRUNK TYPE	2-6
2.4.2 SLC® TYPE	2-6
2.4.3 E & M TYPE	2-6
2.5 DISPLAY CONFIG 1 and CONFIG 2	2-7
2.5.1 MODE	2-7
2.5.2 DIGit DETection	2-8
2.5.3 SLC® MSG	2-8
2.5.4 SLC® Activity Message	2-9
2.5.5 T/t Mask (single-tone event selection)	2-9
2.6 RS232 CONFIG	2-9
2.6.1 BAUD RATE	2-9
2.6.2 PARITY	2-10
2.6.3 CR DELAYsec	2-10
2.7 SECURITY CONFIG	2-10
2.7.1 PASSWORD	2-10
2.7.2 SETUP PROTECT	2-10
2.8 PRINT CONFIG	2-11
2.8.1 off	2-11
2.8.2 all calls, events only	2-11
2.8.3 all calls, events & details	2-11
2.8.4 flawed calls, events only	2-11
2.8.5 flawed calls, events & details	2-11
2.9 CLOCK CONFIG	2-12
2.10 AM8a CONFIG	2-12
3. EMULATE PARAMETERS	3-1
3.1 LOOP EMULATE	3-1
3.1.1 VOLTAGE	3-1
3.1.2 LENGTH	3-1

3.2	TERMINATION EMULATE.....	3-1
3.2.1	2.16uf	3-1
3.2.2	DC HOLD	3-2
3.3	DIALING EMULATE	3-2
3.3.1	LOOP TYPE.....	3-2
3.3.2	START SIGNAL	3-2
3.4	PULSE EMULATE.....	3-2
3.4.1	SPEEDpps	3-2
3.4.2	BREAK%.....	3-2
3.4.3	INTRDIGITms	3-2
3.5	DTMF/MF EMULATE 1	3-3
3.5.1	HI:dBm/hz%	3-3
3.5.2	LO:dBm/hz%.....	3-3
3.6	DTMF/MF EMULATE 2	3-3
3.6.1	ON/OFFms.....	3-3
3.7	SEND TONE EMULATE.....	3-4
3.7.1	LEVELdBm.....	3-4
3.7.2	FREQUENCYhz.....	3-4
3.8	DIAL TONE EMULATE 1.....	3-4
3.9	DIAL TONE EMULATE 2.....	3-4
3.9.1	T1:dBm/hz.....	3-5
3.9.2	T2:dBm/hz.....	3-5
3.9.3	DL SNDms	3-5
3.10	RECALL EMULATE.....	3-5
3.10.1	HOOKFLASHms.....	3-5
3.10.2	LINE UNBALms	3-5
3.11	RINGING EMULATE 1	3-6
3.11.1	ON/OFFms.....	3-6
3.12	RINGING EMULATE 2	3-6
3.12.1	VOLTAGEvrms	3-6
3.12.2	FREQUENCYhz.....	3-6

3.13 START TIME EMULATE	3-7
3.13.1 DLY:BGN/ENDms.....	3-7
3.13.2 WINK:BGN/DURms	3-7
3.14 SF EMULATE	3-7
3.14.1 LEVEL	3-7
3.14.2 FREQ+%hz	3-7
4. ANALYSIS PARAMETERS.....	4-1
4.1 HOOK ANALYZE.....	4-1
4.1.1 FLASHms(min).....	4-1
4.1.2 DISCONNECTms(min)	4-1
4.2 STRT SIG (START SIGNAL) ANALYZE: EXPECTED TYPE.....	4-2
4.2.1 dialtone/wink	4-2
4.2.2 dialtone/delay	4-2
4.2.3 dialtone/...	4-2
4.3 DT STRT (DIALTONE START) ANALYZE: DIALTONE RCVDms (min/max).....	4-2
4.4 DLY STRT (DELAY START) ANALYZE	4-3
4.4.1 STRT BGNms(min/max)	4-3
4.4.2 ENDms(min).....	4-3
4.5 WINK STRT	4-3
4.5.1 WINK BGNms(min).....	4-3
4.5.2 DURms(min/max).....	4-3
4.6 PULSE ANALYZE 1	4-4
4.6.1 SPEEDpps(min/max)	4-4
4.6.2 BREAK%.....	4-4
4.7 PULSE ANALYZE 2	4-4
4.7.1 INTERDIGITms(min).....	4-4
4.8 DTMF/MF ANALYZE 1	4-5
4.8.1 LO BANDdB(min/max)	4-5
4.8.2 HI BANDdB	4-5

4.9 DTMF/MF ANALYZE 2	4-5
4.9.1 FREQ%(max)	4-6
4.9.2 TWISTdB(min/max)	4-6
4.9.3 DTMF Frequencies	4-6
4.9.4 MF(R1) Frequencies	4-7
4.10 DTMF/MF ANALYZE 3	4-8
4.10.1 TONE ON/OFFms(min)	4-8
4.10.2 GUARDms	4-8
4.11 THRESHOLD ANALYZE	4-8
4.11.1 TONEdBm(min)	4-8
4.11.2 OFF HKvdc(min)	4-9
4.11.3 Procedure to Set OFF HKvdc(min) Threshold	4-9
5. AUTO AND MANUAL DIALING	5-1
5.1 STORE AUTODIAL SEQUENCE	5-1
5.2 SELECT AND USE AUTODIAL SEQUENCE	5-2
5.3 MANUAL DIALING	5-2
6. METER DISPLAY	6-1
6.1 MEASURE/SCALE MENU	6-1
6.2 MEASURE DISPLAY (MAKING MEASUREMENTS)	6-1
6.3 METER SELECTIONS AND CONNECTIONS	6-2
6.4 LOOP START, GROUND START, DID – ANALOG MEASURE	6-7
6.4.1 V t-r dc or ac	6-7
6.4.2 V cm dc or ac	6-7
6.4.3 V t-g dc or ac	6-7
6.4.4 V r-g dc or ac	6-7
6.4.5 It(mA) dc	6-7
6.4.6 Tone	6-8

6.5 E & M and SF – ANALOG MEASURE	6-9
6.5.1 TX Vt-r or RX Vt-r, dc or ac.....	6-9
6.5.2 TX Vcm or RX Vcm, dc or ac.....	6-9
6.5.3 Ve or Vm, dc or ac	6-9
6.5.4 Vsb or Vsg, dc or ac.....	6-10
6.5.5 TX Tone or RX Tone.....	6-10
6.6 E & M and SF – ANALOG MEASURE	6-11
6.6.1 TX1 Vcm or TX2 Vcm, dc or ac	6-11
6.6.2 RX1 Vcm or RX2 Vcm, dc or ac	6-11
6.6.3 TX1 Tone or TX2 Tone	6-11
6.6.4 RX1 Tone or RX2 Tone	6-12
6.6.5 RX1 dBdsx or RX2 dBdsx.....	6-12
6.6.6 RX1 dBdsx or RX2 dBdsx in Emulation Mode.....	6-12
6.6.7 RX1 dBdsx or RX2 dBdsx in Monitor Mode.....	6-12
6.7 NOISE MEASURE.....	6-12
6.8 PCM1 and PCM 2 BIPOLAR VIOLATION (COUNT AND STATUS) MEASURE	6-13
6.8.1 BPV	6-13
6.8.2 FERR.....	6-14
6.8.3 CRC.....	6-14
6.8.4 SLIPS	6-14
6.8.5 YELLOW	6-14
6.8.6 BLUE	6-14
6.8.7 STATUS BLUE.....	6-14
6.8.8 STATUS YELLOW	6-14
6.9 PCM 1 OR PCM 2 FRAME SYNC MEASURE	6-14
6.10 PCM1 and PCM 2 TX OR RX A/B MEASURE	6-15
6.10.1 T1 Time-Slot to Voice Channel Assignment.....	6-15
6.10.2 SLC®96 Mode I Time-Slot to Voice Channel Assignment	6-15
6.10.3 SLC®96 Mode II Time-Slot to Voice Channel Assignment	6-15

6.11 SLC®96 MODE I OR II MESSAGES	6-17
6.11.1 ALARM TX or RX	6-17
6.11.2 PROTECTION TX or RX	6-18
6.11.3 MAINTENANCE TX or RX	6-18
6.11.4 SLC®96 II Concentrator Field Messages	6-19
7. RS232 ENTRIES AND PRINTOUTS.....	7-1
7.1 RS232 COMMAND DESCRIPTION	7-1
7.1.1 Terminal Commands	7-2
7.1.2 Printer Commands	7-2
7.1.3 Setup Menu Commands for CONFIG, EMULATE, and ANALYZE	7-2
7.1.3.1 Display Menu	7-3
7.1.3.2 Change Parameter	7-3
7.1.3.3 Print Menu	7-3
7.1.4 AUTO DIAL Setup Commands	7-3
7.1.5 ON-OFF (Control Toggle) Commands	7-4
7.1.6 CALL INITIATE (Signaling) Commands	7-4
7.1.7 EVENTS DISPLAY Commands	7-4
7.1.8 METER DISPLAY Commands	7-4
7.2 PRINTOUTS	7-16
7.2.1 off	7-16
7.2.2 all calls, events only	7-16
7.2.3 all calls, events & details	7-17
7.2.4 flawed calls, events only	7-17
7.2.5 flawed calls, events & details	7-17
7.2.6 Manual Short Print	7-18
7.2.7 Manual Long Print	7-19
7.3 RS232 REAR-PANEL CONNECTIONS	7-22
7.3.1 Printer Cable (48-0084) Connection	7-22
7.3.2 Chaining Cable (48-0083) Connection	7-23
7.3.3 Chained Unit Addressing Command	7-23

8. AM8a TECHNICAL SPECIFICATIONS	8-1
9. WARRANTY, SERVICE, AND CALIBRATION	9-1
9.1 WARRANTY	9-1
9.2 SERVICE POLICY	9-1
9.3 CALIBRATION POLICY	9-1
9.4 RETURN OF UNIT	9-2
A. APPENDIX A: METER DISPLAY	A-1
A.1 PCM Operations and Data Flow	A-1
A.1.1 MODE CONFIG Menu Settings	A-1
A.1.2 CIRCUIT CONFIG Menu Settings	A-6
A.1.3 PCM CONFIG 1 and CONFIG 2 Menu Settings	A-7
A.1.4 TRUNK CONFIG Menu Settings	A-9
A.1.5 DISPLAY CONFIG Menu Settings	A-9
A.1.6 EMULATE Menu Settings	A-9
A.1.7 ANALYZE Menus	A-9
A.2 PCM Connection Diagrams	A-10
A.2.1 Monitoring Connections	A-10
A.2.2 ANALYZE Menus	A-10

Table of Contents

(18-0037)

AM8a Instruction Manual

List of Figures

Figure 1-1. AM8a Front Panel.....	1-1
Figure 1-2. AM8a Events Display	1-4
Figure 1-3. Signaling Status LEDs.....	1-14
Figure 6-1. Cables for AM8a Front Panel Test/Meter Connections	6-3
Figure 6-2. Loop/Ground Start and DID Analog Test/Meter Front Panel Connections.....	6-4
Figure 6-3. E & M and SF Test/Meter Front Panel Connections.....	6-5
Figure 6-4. PCM T1/SLC®96 Test/Meter Front Panel Connections	6-6
Figure 6-5. SLC®96 Mode 1 Channel Number to Time Slot Assignments	6-16
Figure 6-6. SLC®96 Alarm Conditions Meter Display	6-17
Figure 6-7. SLC®96 Alarm Conditions Meter Display	6-18
Figure 6-8. SLC®96 Alarm Conditions Meter Display	6-18
Figure 7-1. Event-only Printout	7-16
Figure 7-2. Events & Details Printout (Monitor Mode)	7-17
Figure 7-3. Events & Details Printout (Emulate Mode).....	7-18
Figure 7-4. Manual Short Print (Meter Display Example).....	7-18
Figure 7-5. Manual Short Print (EMULATE Analog Switch, Te, PCM Examples).....	7-19
Figure 7-6. Manual Long Print (Meter Display Example)	7-20
Figure 7-7. Manual Long Print (Setup Example)	7-21
Figure 7-8. AM8a Rear Panel Connections.....	7-24
Figure 7-9. RS232 Printer Cable	7-25
Figure 7-10. RS232 Chaining Cable.....	7-25

Figure A-1. Monitor PCM Processing Diagram.A-2
Figure A-2. Emulate PCM Processing Diagram.A-3
Figure A-3. Rpt (Repeat) 1 to 2 PCM Processing Diagram.....A-4
Figure A-4. Rpt (Repeat) 2 to 1 PCM Processing Diagram.....A-5
Figure A-5. Monitor PCM Connection Points.....A-6
Figure A-6. Emulate and Repeat (Drop and Insert) PCM ConnectionsA-7

List of Tables

Table 7-1. RS232 Terminal Commands	7-4
Table 7-2. RS232 Printing Commands	7-5
Table 7-3. RS232 CONFIGuration Menu Commands	7-6
Table 7-4. RS232 EMULATE Menu Commands	7-9
Table 7-5. RS232 ANALYZE Menu Commands	7-10
Table 7-6. RS232 Auto Dial Setup Commands	7-12
Table 7-7. RS232 On-Off (Control Toggle) Commands	7-13
Table 7-8. RS232 Call Initiate (Signaling) Commands	7-13
Table 7-9. RS232 Events Display Commands	7-14
Table 7-10. RS232 Meter Display Commands (Analog Voltage Measurements)	7-14
Table 7-11. RS232 Meter Display Commands (Meter Selections)	7-14
Table 7-12. RS232 Meter Display Commands (PCM Measurements)	7-15
Table 7-13. RS232 Meter Display Commands (Noise Measurements)	7-16

Table of Contents

(18-0037)

AM8a Instruction Manual

1. FRONT PANEL OPERATION

1.1 FRONT PANEL PROGRAMMING METHODS

The following sub-sections describe the basic methods for programming the AM8a through the front panel. Refer to Sections 2 through 6 for details on the parameters which may be entered. Refer to Section 7 for the RS232 Commands that provide the means to duplicate front panel operations from a terminal. (Figures 7-3 through 7-5 may also be used as a quick-reference to CONFIGURE, EMULATE, and ANALYZE menu parameter descriptions.)

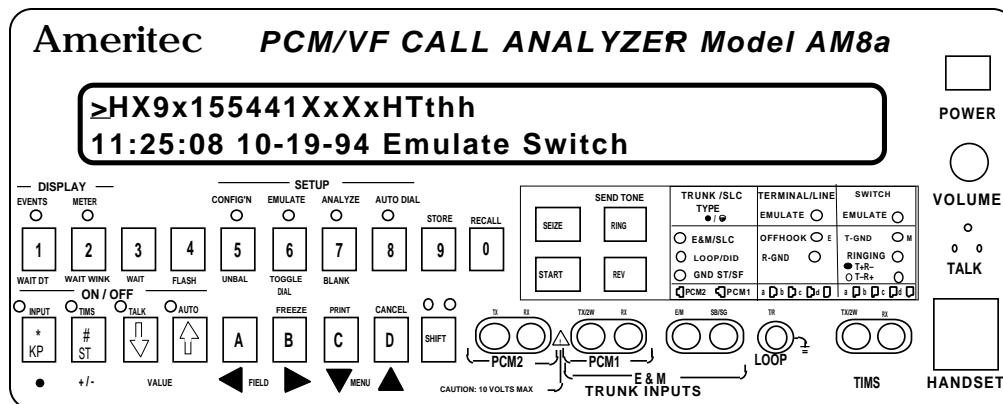

Figure 1-1. AM8a Front Panel

1.1.1 The SHIFT Key: Some keys may have as many as three separate functions. The SHIFT key (see figure 1-1) controls access to each one of these.

- The No-Shift (or "Data Entry") functions for each key are either listed on the center of the key itself (e.g. 1 through 0, *, #, A, B, C, D), or appear below the key in black type (• (decimal point), +/- (plus or minus sign toggle), VALUE, and MENU). These keys are usually for data entry, dialed number sequence entry, or for scrolling through fields and parameters on the LCD display. both LEDs above the SHIFT key must be off.
- Pressing the SHIFT Key once causes the green LED above it to come on and activates the functions described in green type above the Data Entry keys.

- Pressing the SHIFT key twice causes the red LED above it to come on, signifying that functions described in red type beneath the Data Entry keys are available.
- Pressing the SHIFT key a third time returns to the No-Shift functions.

Example: To select the CONFIG'N (Configuration) Setup mode:

9. Press the SHIFT Key until green light comes on.
10. Press CONFIG'N [5] in the SETUP area of the Front Panel. The green LED over the key is then lighted for as long as CONFIG'N is in use; but, the green LED over the SHIFT Key goes OFF and the [5] key is free for data entry.
11. Configuration parameters can then be accessed and revised via menus displayed on the LCD display.

1.1.2 Arrow Keys: The SETUP displays that appear on power-up represent the current values of the various parameters. To input new values:

- All menu screens progress from one set of parameters to another within the CONFIG'N, ANALYZE, or EMULATE SETUP parameters. To change menus, press the ▼ MENU ▲ keys (also labeled "C" and "D" for data entry functions). The menu descriptions in this manual are sequenced in accordance with the pressing of the ▼ MENU ▲ key.
- After selecting a desired menu, move left or right to a particular parameter field by pressing the ◀ FIELD ▶ keys (also labeled "A" and "B" for data entry functions).
- Once in the field, use the ↕ VALUE ↕ keys (also labeled for ON/OFF, "TALK", and "AUTO") to scroll through the possibilities. After you have located your choice, you "enter" it into the system simply by moving to the next field (step 2) or by changing menus (step 1).
- Numerical data may be directly keyed in or you may use the ↕ VALUE ↕ keys to scroll to the desired value. The entry is made by moving to another field or menu. For most numeric values, direct key-in will cause leading zeroes to fill the field to the left. These digits are cleared when the next field is selected.

- When the ◀FIELD▶ key is pressed while at the first field of a menu, the previous menu will be displayed and the data that was displayed will be entered (within the permitted range). Similarly, pressing the ◀FIELD▶ key at the last field will display the next menu.

NOTE: The range of numerical values are listed under the Technical Specifications (and in the figures that describe RS232 Commands in Section 7), and you cannot input data that exceeds the maximum of the range given. If you do key-in a larger (or smaller) number, the largest (or smallest) allowable value will be entered.

1.2 EVENTS AND METER KEYS AND DISPLAY

The EVENTS and METER keys in the DISPLAY area on the front panel are used to select test results and measured data. Sub-sections 1.2.1 through 1.2.4 describe the kinds of data provided by pressing these keys (the [SHIFT] key must first be pressed so that its green LED is lighted):

1.2.1 EVENTS ([SHIFT][1]) Key: This causes the Call Event characters to appear on the first line of the display (Figure 1-2). The EVENTS LED will also begin flashing (unless FREEZE has been activated - see 1.5.1). Up to 40 characters may be displayed at one time, but the display may be scrolled with the ◀FIELD▶ keys to display a total of 80 characters.

A flashing digit or event indicates that the event was generated from the Analog Switch ("far end" for PCM). A steady-state display indicates that the event was generated from the analog Te/Line ("near end" for PCM); see note under 1.2.2 for exceptions.

The second line of the Events Display gives a complete analysis of an event. Position the cursor on whatever character of the first line you choose by using the ◀FIELD▶ keys. The second line of the display immediately indicates the available data for that event.

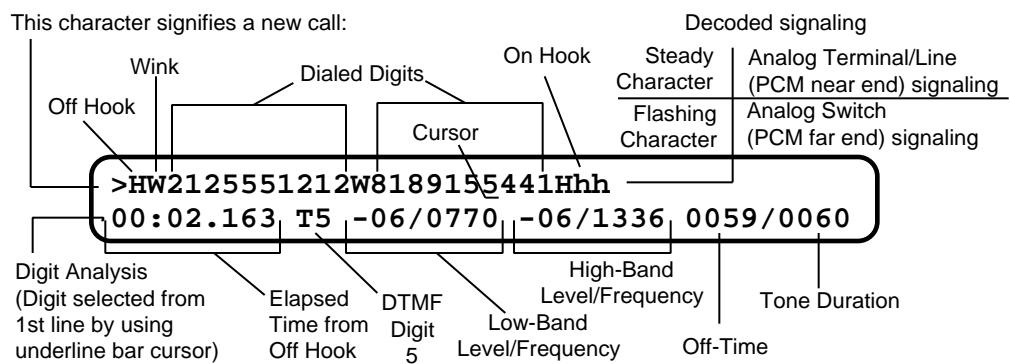

NOTE: A flashing field in the 2nd line indicates a value that is outside of the range specified by the ANALYZE parameter

Figure 1-2. AM8a Events Display

1.2.2 Events Display Character Set: A list of the possible characters which may be displayed on the Events Display follows. Following each description is a sample of what the second line of the display would show if the character were selected for analysis.

- Upper-case characters represent the beginning of an event.
- Lower-case characters represent the end of an event.
- Flashing characters indicate the event originated from the switching (far end) equipment.
- Non-flashing characters indicate the event originated from the Te/Line (near end) equipment.

NOTE: Some non-flashing events such as Tones on a 2-wire circuit may have originated from either the switch or the Term/line equipment. The direction of these events cannot be determined.

- > indicates the beginning of a new call sequence. ">" will appear only at the first position if the CONFIG DISPLAY:MODE parameter is set for "new call reset". More than one new call sequence (with its beginning ">" in some other position) is only possible if the DISPLAY:MODE parameter is set for "manual reset" or "scroll". The time and date of the event and setting from MODE:MODE parameter is shown on the second line when this character is selected.

15:00:15 02-28-92 Emulate (or Monitor) Switch (or Term/Line)

0-9 dialed digits. (*, #, and A, B, C, or D may also be dialed digits; see 1.2.3.)

? means that the AM8a detected a dual-frequency tone that did not meet the specifications to be either a Tone Dial Digit or a Call Progress Tone. These occur mostly on a voice line which has speech on it. Set the DIG DET parameter (see 2.5.2) to "narrow" or "limit" to eliminate the "?"s.

If DIG DET is set to "wide", increasing the GUARD time parameter in the ANALYZE setup (see 4.10.2) may help to reduce the number of "?"s encountered. Invalid events may also be dial pulses if there are more than 15 pulses.

00:05.847	T?	-18/1161	-11/1646	1637/0025
00:07.247	P?	09.9 pps	52%	768 ms

NOTE: For SLC-96 II (Mode II) events, LDS means "Local Digital Switch", and "RT" means Remote Terminal. For more information refer to 2.3.2, 2.5.3 and 2.5.4.

a is SLC@96 II Activity RT to LDS

b is SLC@96 II Activity Update RT to LDS

c is SLC@96 II Looping Test

d is SLC@96 II Assignment Update Request RT to LDS

e is SLC@96 II Idle/Trunk De-assignment update (E & M circuit)

f is SLC@96 II No Alarm RT to LDS

F indicates the AM8a received a hook flash.

00:03.215	Flash	489ms
-----------	-------	-------

H will appear when an "OFF HOOK" (seizure) has been detected. When "H" appears as the first event, it signifies the beginning of that call sequence. All events which follow will have an occurrence time relative to the "H". An "H" which occurs later in the call sequence indicates a distant "OFF HOOK" (answer supervision).

00:00.000	Off Hook
-----------	----------

h indicates the detection of an "ON HOOK".

00:01.385	On Hook
-----------	---------

i is SLC@96 II Trunk Assignment LDS to RT

j is SLC@96 II Assignment Update LDS to RT

- k** is SLC@96 II Looping Test
- l** is SLC@96 II Activity Update Request LDS to RT
- m** is SLC@96 II Idle/Trunk De-assignment update (E & M circuit)
- n** is SLC@96 II COT Trunk De-assignment
- P** indicates the detection of reverse polarity on the line pair. This is used on Loop circuits to indicate answer supervision. It will also indicate the detection of a Delay START SIGNAL if EXPECTED or a Wink if the Wink duration exceeds 999ms.
- 00:01.325 Supervision Begin**
- p** appears after the polarity reversal has been removed. The analysis line will display the time answer supervision was removed.
- 00:05.398 Supervision End**
- R** appears when ringing is detected.
- 00:03.332 Ring Begin 101.2 v 20.5 Hz**
- r** will appear when the ring voltage is removed.
- 00.05.430 Ring End**
- T** appears when the AM8a detects a single tone.
- 00:10.209 Tone Begin**
- t** will appear when the single tone is removed.
- 00:25.998 Tone End -13dBm 1004Hz**
- W** will appear when a "WINK" is detected or generated.
- 00:00.355 Wink 250ms**
- X** indicates the beginning of a Call Progress Tone. A call progress tone consists of a dual tone detected which does not meet the frequency requirements of tone dialing. This includes Dialtone, Line busy, Reorder, and Ringback.
- 00:00.285 Call Progress Begin**
00:00.316 Dial Tone Begin

- x signifies the end of the call progress tone. Selecting this for analysis will display the Level and Frequency for each of the tones.

```

00:00.756  CP End   -17/480 -16/620
00:00.501  DT End   -13/350 -13/440

```

- y is SLC®96 II Trunk De-assignment LDS to RT.

1.2.3 Dialed Digits (O - 9, *, #, A, B, C, D): Digits appear whenever a valid dialed digit is detected. A digit is considered valid if it meets the following criteria:

- The level of a tone dial digit exceeds the Threshold programmed in the ANALYSIS Setup menu.
- The Low and High band frequency components must be within + 3.5 % of the nominal frequency for Tone Dial digits.
- The Speed is between 5 and 25pps and the % Break is between 40 and 85 % for Pulse dialing.
- A KP digit must be received before any other MF digit will be analyzed.
- An ST, ST3P, STP, or STP2 digit (ST, A, B, or C key) must be received to end the MF digit analysis.

The following are examples of digit events and details:

EVENT	DETAIL				
5	00:13.385 T5	-06/770	-06/1336	0059/0060	DTMF
1	00:05.325 M1	-07/700	-07/900	0070/0071	MF(R1)
2	00:04.603 P2	09.9pps	56%	699ms	Pulse

NOTE: MF(R1) digits will not be seen if DIALTONE is used as a Start Signal.

1.2.4 METER ([SHIFT][2]) Key: When the METER key is pressed, measurements and test statistics are available for voltage, current and PCM evaluations, including phase relationships between two T-1 spans. Use the MENU and VALUE keys to select the Meter mode. Section 6 describes the meter functions.

1.3 SETUP AREA

The Setup area on the front panel controls the programming of the AM8a unit for all test procedures. It is here that required parameters are set for configuration, emulation, analysis and auto dialing functions. Each of these areas are briefly described below, and specific information on all the parameters that are available in each Setup category is shown in Section 2, 3, 4, and 5.

1.3.1 CONFIG'N ([SHIFT][5]) Key: When selected, the menus identified by "CONFIG" are presented. All the parameters for basic configuring of the line can be set in this mode (software version is also shown). Settings include:

- Whether the AM8a is to be used as a switch (CO) or terminal/line.
- Which trunk type is being monitored or emulated.
- Time and date.
- RS232 baud rate, parity, and CR delay.
- Flags for SLC®96 display options.
- Manual or new-call display reset.

1.3.2 EMULATE ([SHIFT][6]) Key: When selected, the menus identified by "EMULATE" are presented. This mode allows access to parameters that control timing of AM8a generated events. Settings for voltage, frequency and timing are to be made here, as well as for impedance, ringing voltage, dial tone and dial pulse, recall (flash and unbalance), and tone dialing.

1.3.3 ANALYZE ([SHIFT][7]) Key: When selected, the menus identified by "ANALYZE" are selected. These parameters are used to instruct the AM8a on how to interpret events the events it encounters. It is also used to set thresholds for flagging and printing errors or flaws in a call sequence.

1.3.4 AUTO DIAL ([SHIFT][8]) Key: When selected, the dialed number display is presented. Stored dialing sequences which can be automatically recalled are set in this display. Up to 11 dialed sequences can be stored in Auto Dial. Each sequence can contain up to 60 characters. This display is shown in Section 5.

1.4 CONTROL ON/OFF KEYS

Additional control of configuration on the AM8a is available through ON/OFF function keys on the lower left of the front panel. (See Figure 1-1.) The green LED indicates when the function is ON. The following descriptions review the specific configuration control provided:

1.4.1 INPUT ([SHIFT][*, KP]) Key: This key controls the AM8a connection to the selected line being emulated or monitored. Connections are described in Section 6 along with metering of circuits.

- ON: the test set has full access to the lines selected; this is the standard condition.
- OFF: all AM8a interfaces to the line jacks change to high impedance or open circuits that will not interfere with the line under test.

NOTE: The OFF position is a built-in safety feature that prevents glitches during any rearrangement of the external connections during AM8a configuration changes. In addition, if certain trunk configuration parameters are changed, INPUT is forced OFF.

1.4.2 TIMS ([SHIFT][#, ST]) Key: This key controls connection of a Transmission Impairment Measurement Set (a TIMS such as the Ameritec AM5XT) to test the transmission quality of the line. The TIMS is connected to the TIMS jacks on the front panel. The key provides a three-position toggle.

NOTE: For PCM1 or PCM2, the TIMS jacks are connected internally to the selected CHANNEL. Refer to the Appendix that describes PCM operation.

- 1 (green LED ON): When on, the TX and RX circuitry in the AM8a is connected to the TIMS 2W/TX and RX jacks. For 2W circuits or analog LOOP, the TIMS 2W/TX jack is used. For 4W circuits, both jacks are used.
- 2 (green LED flashes): When in a monitor PCM mode, the TIMS jack RX and TX/2W connections to the AM8a circuitry are reversed.
- 3 (green LED OFF): The TIMS jacks are Open and there is no connection to the AM8a circuitry.

1.4.3 TALK ([SHIFT][\downarrow VALUE]) Key: This control allows the operator to talk over the circuit under test.

- ON: Enables the speakerphone function of the unit, using the front-panel microphone and speaker. If a handset is connected, the front panel microphone and speaker are disabled, and the handset functions as a telephone. To avoid noise and false events, ON should not be enabled until the voice connection is made.
- OFF: Speakerphone (or handset) is inoperative.

1.4.4 AUTO ([SHIFT][VALUE \uparrow]) Key: This control applies only when the AM8a is used in emulation. It is not used when set to Monitor.

- ON: If EMULATE has been activated, pressing "SEIZE" key will cause the AM8a to go Off Hook, and emulate the functions associated with the Calling Party (i.e. detect the expected start dial signal and outpulse AUTO DIAL numbers) of the Trunk Type programmed in the CONFIG'N Setup menu.

The AM8a will perform the functions associated with switching equipment of the selected Trunk Type when an incoming seizure is detected. (i.e. provide programmed start dial signal).

- OFF: The AM8a generates individual emulation events only in response to manual input.

1.5 MENU/DATA CONTROL KEYS

1.5.1 FREEZE ([SHIFT][B]) Key: Freeze allows the user to Freeze the Events Display to halt the display update as new events are encountered. FREEZE is most useful in viewing specific events embedded within a long call sequence.

- ON: Events Display will indicate a ",," to alert the user that a FREEZE has occurred. In addition, the green LED for DISPLAY EVENTS (over [1] key) will go on steady.
- OFF: To disable the Freeze, use the CANCEL key. The green LED above EVENTS will resume flashing, and the Events Display will be updated as new events arrive.

1.5.2 PRINT ([SHIFT][C]) Key: The PRINT key allows the user to obtain a RS232 report for a selected section or display. The PRINT key can be used to print two types of reports, "Short Print" and "Long Print". For examples, refer to Section 7.

- **Short Print:** Press [SHIFT] then [PRINT] for a Short Print. The Short Print will provide a printout of the selected display event or Setup parameters. The printout will consist of only the Events or the selected Setup.
- **Long Print:** Press [SHIFT] then [PRINT] and HOLD PRINT for longer than two (2) seconds. The Long Print will provide a printout of the selected Display or Setup section. The printout will consist of both Events **AND** Details, or **ALL** Setup parameters.

1.5.3 CANCEL [SHIFT][D] Key: The CANCEL key is to disable the FREEZE of the Display. It is also used to clear the display of past Events when desired. While in the Meter Display, use the CANCEL to zero the PCM counters and to align the FRAME SYNC display. In PCM Monitor mode with random channel select, this key will abort the currently-selected channel so that another channel can be monitored.

1.6 SIGNALING KEYS

The signaling keys are used to initiate a call event when Emulate mode has been selected by configuration parameter "MODE: MODE emulate"(2.1).

If the AM8a has been placed in the AUTO mode, the AM8a will perform some functions automatically, as appropriate to its "MODE: IMITATE" "switch" or "te/line" setting, when it receives signals from the circuit under test.

If the AM8a is not in AUTO mode, the appropriate key must be pressed when the operator sees the incoming event displayed.

1.6.1 SEIZE Key: This key alternately puts the line being emulated in an Off-Hook or On-Hook condition.

1.6.2 START Key: This key transmits the "Start" signal according to the "Start Signal" parameter that has been defined by the "DIALING: START SIGNAL" EMULATE parameter.

- For "dial tone", another press of the key will remove it.
- For "delay" start signal (similar to "wink"), another press before it's programmed end time (START TIME: DLY: /ENDms) will terminate it.
- For "wink", each press will send a "wink" of the programmed duration (WINK: /DURms).
- For "immediate" dial, it has no function for a Te/Line that is set for analog (loop) operation.

1.6.3 RING Key: This key sends ringing to alert the terminal equipment that a call is coming from the AM8a. Ringing will be applied according to the "RINGING:" parameters given in the EMULATE Setup. Pressing the RING key again will remove the ringing signal.

CAUTION: *Placing an excessive (>5 REN) Load across Tip Ring during Ring application may cause the AM8a to reset. Ringing will not be generated if any of the following conditions exist:*

1. **Low battery indication on display.**
2. **Loop is seized (i.e. Off Hook).**
3. **If > 14mA ring trip current is detected.**
4. **An excessive ringer load exists for several minutes.**
5. **Unit is emulating a TE/LINE in analog loop mode.**

1.6.4 REV Key: This key controls battery polarity for the line under test when emulating a Switch. Each press changes the polarity on the line. This key is equivalent to the SEIZE key when Emulating TE/LINE equipment.

1.6.5 SEND TONE ([SHIFT][RING]) key: This is a secondary function of the RING key. Press [SHIFT] then [RING] and the AM8a will send a single tone at the Level and Frequency programmed in the EMULATE "SEND TONE:" setup parameters.

1.7 DATA ENTRY KEYS FOR SIGNALING

In addition to numerical SETUP parameter values (and the SHIFT functions printed above some of them in green), the two rows of Data Entry keys provide all 16 DTMF (Dual Tone Multifrequency) digits for signaling, all 15 MF digits, and all 10 dial pulse digits.

Keys 1-7 also activate dialing sequence signaling functions printed in red beneath them (after SHIFT has been pressed twice so its red LED is on). These additional signaling functions include:

- 1.7.1 WAIT DT ([SHIFT][SHIFT][1]) Key:** This key causes the AM8a to stop dialing and wait for Dial Tone before continuing. "P" will appear where this is entered into an AUTO DIAL location.
- 1.7.2 WAIT WINK ([SHIFT][SHIFT][2]) Key:** This key causes the AM8a to stop dialing and wait for a valid wink before continuing. "W" will appear where this is entered into an AUTO DIAL location.
- 1.7.3 WAIT ([SHIFT][SHIFT][3]) Key:** This key gives a fixed wait of 3 seconds in dialing. "-" will appear where this is entered into an AUTO DIAL location.
- 1.7.4 FLASH ([SHIFT][SHIFT][4]) Key:** This key gives a momentary On-Hook state, with duration determined by the "FLASH" parameter entered in ANALYZE. "F" will appear where this is entered into an AUTO DIAL location.
- 1.7.5 UNBALANCE [SHIFT][SHIFT][5] Key:** With this key, a momentary unbalanced condition (resistance on the conductors unequal with respect to ground) is applied to the line for a duration specified under ANALYZE. "U" will appear where this is entered into an AUTO DIAL location.
- 1.7.6 TOGGLE DIAL ([SHIFT][SHIFT][6]) Key:** If different dialing types are to be used in the same call, this key offers a method of selecting the changes. Each time a Toggle Dial is encountered, it changes dialing modes. The sequence is: TT, DP, MF, in rotation. "T" will appear where this is entered into an AUTO DIAL location.
- 1.7.7 BLANK ([SHIFT][SHIFT][7] Key:** Inserting a blank into an AUTO DIAL number will stop the dialing sequence at that point.

1.8 SIGNALING STATUS LEDs

The Signaling Status LEDs show the TRUNK TYPE that the AM8a is IMITATING and whether it is operating as an analog terminal/line or switch, or as a PCM terminal. Figure 1-3 shows these indicators and identifies the menu parameters which set up the operation (see Section 2 sub-sections for appearance of menus and more information on the parameter selections). For more information on the signaling keys shown in the figure, refer to 1.6.

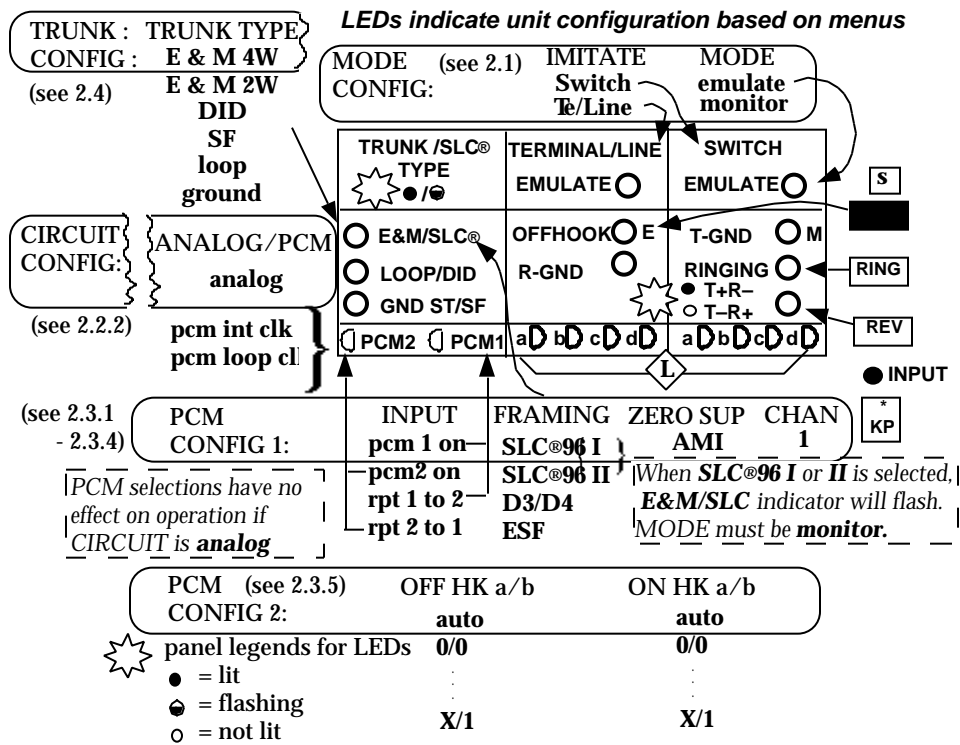

Figure 1-3. Signaling Status LEDs

☆ a, b, c, d LEDs indicate signaling bits for the PCM CHANNEL selected. They will scroll if there is no frame sync (see Section 6, sub-sections 6.9 and 6.10 for meter display of frame sync and bits). When frame sync is established, bits will be lit in patterns to indicate CHANNEL conditions.

Ⓢ Typical switch actions resulting in LED indication as condition is detected. See sub-section 1.6 for more information.

1.9 STORE SETUP

The STORE function will save up to 20 different Configuration setups and up to 20 different Emulate/Analyze parameter sets. To store parameters in either SETUP category, press [SHIFT] then [STORE], followed by the appropriate number as indicated in the following sequence:

NOTE: The STORE function will **NOT** operate while the AM8a is set to the EVENTS Display or is displaying the DATE/TIME. Current parameters for EMULATE/ANALYZE will be stored if their locations are specified, even if the CONFIG'N SETUP mode is selected (and vice verse).

1. Press [SHIFT] (so its green LED is on) then [STORE][n][n].
 nn = 00 - 19 for CONFIG
 20 - 39 for EMULATE/ANALYZE
2. After the storage location has been input, one of the following displays will appear with instructions for the next actions.

STORE TRUNK CONFIGURATION ?
PRESS "MENU UP" (YES), OTHER KEYS (NO)

Pressing Menu up will store the current Config setup, any other key will abort the store sequence.

STORE EMULATE/ANALYZE ?
PRESS "MENU UP" (YES), OTHER KEYS (NO)

Pressing Menu up will store the current Emulate/Analysis setup, any other key will abort the store sequence.

;; CAN NOT STORE, SETUP PROTECTED
PRESS ANY KEY TO CONTINUE

This display will appear if the setup is protected. If storage is still desired, go to the Config Setup menu and disable the memory protect. Then repeat the Store sequence. Be sure to enable the memory protect upon completion of the storage.

NOTE: Some Configuration parameters are not included in a stored Configuration. They are: Protect/Unprotect, Baud Rate, Parity, Date/Time, Password, and Display Mode. Since they are not stored, they also cannot be recalled; values that appear on power up are whatever were last set.

1.10 RECALL SETUPS

RECALL is used to recall stored Configuration, Emulate, and Analysis parameters when in a Setup mode. It may also be used to recall pre-stored "Auto Dial" numbers when Emulating Term/Line equipment while in the Events Display mode.

1.10.1 RECALL Setup Parameters:

1. Select one of the Setup modes. (CONFIG'N, EMULATE, or ANALYZE, but not AUTO DIAL.
2. Press [SHIFT] then [RECALL] then [n][n].
nn = 00 -19 for CONFIG'N
20 - 39 for EMULATE/ANALYZE
single [*] to recall ALL parameters before last power-off.
3. The AM8a will recall the setup based on the previously stored parameters for the selected location.

1.10.2 RECALL Auto Dial Sequence:

NOTE: The AM8a must be Configured so that it is expected to dial (i.e: Emulate Te/Line, and Off Hook).

1. Select EVENTS Display.
2. Press [SHIFT] then [RECALL] then [Auto Dial location (0 - 9)] or ["*"] for Last Number Dialed.

NOTE: Last Number Dialed accumulates all out-pulsed digits from "Off- Hook" to "On-Hook" for each call sequence.

1.11 SPEAKERPHONE/AUDIO MONITOR

The speakerphone is located on the front panel, labeled TALK. The VOLUME control adjusts to the level of the speaker. A handset must be plugged into the modular jack labeled HANDSET. The TALK (ON/OFF) key LED must be lighted.

- 1.11.1 Speakerphone in talk mode:** To use the speakerphone the AM8a must be in Emulation mode, because the Talk Mode is used to communicate with the person at the other end of the line. In effect, this uses the AM8a as a speakerphone itself.

Anything spoken into the microphone will go out on the line, and anything coming in will go to the speaker. **To avoid unwanted noise events, do not go into the Talk Mode until the called number has answered.**

- 1.11.2 Handset:** If you plug in the handset, the unit automatically detects it, activates the handset circuits, and the microphone and speaker are deactivated. All other conditions for speakerphone apply to handset.

NOTE: *Refer to Figure 1-1 for Handset connections.*

- 1.11.3 Audio Monitoring:** When numbers are dialed the speakerphone will monitor dial tones, dial digits, and tones from the switch or line. The VOLUME control adjusts the monitor level.

Front Panel Operation

(18-0037)

AM8a Instruction Manual

2. CONFIGURATION PARAMETERS

The following displays show in sequence the types of configuration parameters used to program the AM8a. To use these menus press the CONFIG'N key.

2.1 MODE CONFIG

MODE :	IMITATE	MODE
CONFIG:	switch	monitor

Alternate:	te/line	emulate
-------------------	----------------	----------------

2.1.1 IMITATE: The AM8a can operate as either terminal/line equipment or as switching (CO) equipment.

te/line: The AM8a will perform the functions associated with the terminal or line equipment of the circuit under test. (i.e. seizure, dial out, ring trip, etc.)

switch: The AM8a will provide the functions associated with the switching equipment of the circuit under test. (i.e. battery, start dial signal, ringing, etc.)

2.1.2 MODE: The MODE selects whether the AM8a will emulate or monitor the equipment as selected by the IMITATE parameter.

monitor: The AM8a is non-intrusive to the circuit. Events will be displayed as they occur and the statistics will be recorded for analysis. Call progress tones and dialing will be displayed as they appear.

emulate: The AM8a will provide the signaling IMITATE mode selected. The signals provided are specified by the parameters in the EMULATE menus.

NOTE: Emulate cannot be used with SLC®96 I or SLC®96 II INPUT (see 2.3.1).

2.2 CIRCUIT CONFIG

The Circuit Config menu allows the user to specify the characteristics of the trunk type to be tested.

CIRCUIT:	ANALOG IMPEDANCE	ANALOG/PCM
CONFIG :	900 ohm	pcm loop clk
Alternate:	135 ohm	analog
	600 ohm	pcm int clk
	1200 ohm	

2.2.1 ANALOG IMPEDANCE: This parameter selects the termination used when connected to an analog loop line.

2.2.2 ANALOG/PCM: This parameter allows the selection of direct analog operation or PCM operation. (PCM will function on each voice channel according to the selections made in the TRUNK CONFIG menus.

analog: Selects the analog input jack (LOOP T/R) for connection to the circuit.

pcm int clk: (Internal Clock) the AM8a will generate the clock for PCM framing information. In this case, the AM8a acts as a "Master" via the PCM1 or PCM2 TX jack.

pcm loop clk: (External Clock) uses the PCM signal it receives to obtain framing data. In this mode, the AM8a acts as a "Slave" via the PCM1 or PCM2 RX jack. For testing in repeat (drop and insert) mode the PCM signal with the clock (framing data) must be connected to the PCM1 RX jack. (Refer to 2.3.3).

2.3 PCM CONFIG 1 and PCM CONFIG 2

The PCM CONFIG 1 menu allows the user to select the PCM input, framing, zero substitution code word, and time slot or channel for voice measurements.

PCM	:	INPUT	FRAMING	ZERO SUP	CHAN
CONFIG 1:		pcm 1 on	D3/D4	AMI	1

Alternate:

pcm 2 on	ESF	B8ZS	0, 1 to 24
rpt1 to 2	SLC 96 I	ZCS	or
rpt2 to 1	SLC 96 II		-1 to -96, -97

The PCM CONFIG 2 menu selects the a and b bit coding for off-hook and on-hook conditions. Refer to Section 6.10 for description of the Meter display of these bits.

PCM	:	OFF HK a/b	ON HK a/b
CONFIG 2:		auto	auto

Alternate:

0/0	0/0
0/1	0/1
1/0	1/0
1/1	1/1
0/X	0/X
1/X	1/X
X/0	X/0
X/1	X/1

2.3.1 INPUT: This parameter selects how the input jacks will be used to interface with the PCM link.

pcm1 on: selects the PCM1 jacks for emulate or monitor connection.

pcm2 on: selects the PCM2 jacks for emulate or monitor connection.

rpt 1 to 2: is used during Drop & Insert testing. This mode allow the selected CHANNEL to be used for emulation towards the equipment connected to the PCM1 input jacks; other channels are uninterrupted to PCM2.

rpt 2 to 1: is used during Drop & Insert testing. This mode will allow the selected CHANNEL to be used for emulation towards the equipment connected to the PCM2 input jacks; other channels are uninterrupted to PCM1.

NOTE: In MONITOR mode all channels pass from PCM1 to PCM2 when rpt 1 to 2 or rpt 2 to 1 are selected. See Section 6 for metering the a and b bits to find an idle channel that can be selected for drop and insert testing.

In Drop & Insert testing, the equipment which supplies the "Master" clock for framing must be connected to the PCM1 input jack.

2.3.2 FRAMING: This parameter selects the span framing type assignment that the AM8a can emulate and monitor.

D3/D4: is the most popular type of framing. It uses 12 separate frames in a super-frame. The signaling bits are identified as "a" and "b" bits.

ESF: Extended SuperFrame is another popular type of framing. This type uses 24 frames rather than 12 frames. Its signaling bits are "a, b, c, and d".

SLC®96 I: (SLC® 96 Mode I) monitors 96 channels or data link on four spans (A, B, C, and D). Assignment of channels to time-slots is fixed. Refer to Table 6-5 for these assignments.

SLC®96 II: (SLC®96 Mode II) monitors 96 channels or data link on two spans (A and C). Assignment of channels to time-slots is on as-available basis. Refer to 2.5.4 for use of activity message to determine line groups and active channels.

NOTE: SLC®96 I and SLC®96 II can only be used in monitor mode.

2.3.3 ZERO SUP: Zero Suppression is the way that the AM8a handles a data pattern of all "0's" during transmission.

AMI: (Alternate Mark Inversion) is the standard protocol for T1 spans. AMI does not supply any zero suppression conversions.

B8ZS: (Binary Eight Zero Suppression) will insert two bipolar violations when eight consecutive zeros are encountered. The receiving equipment will recognize this and remove the BPV's and correctly interpret the data.

ZCS: (Zero Code Suppression) will insert a "1" bit to prevent the transmission of eight or more consecutive "0" bits.

2.3.4 CHAN: This parameter is used to select either a PCM time-slot or voice channel. A channel is not passed through when the AM8a is in drop and insert input and emulation mode. Selection options are:

- 0:** Random selection of first time-slot that goes active (monitor only).
- 1 through 24:** T1 time-slot to monitor, emulate, or drop and insert. SLC®96 I time slot to monitor. (See Figure 6-5 for time slot to channel assignment at SLC®96 equipment shelves).
- 1 through -96:** SLC®96 I or II Voice channel to monitor.
- 97:** SLC®96 I or II Data link to monitor (see 2.5.3 and 2.5.4).

2.3.5 OFF HK a/b or ON HK a/b: These parameters set the a and b bit patterns that will be generated or detected as off-hook or on-hook.

AUTO: The bit patterns are set in accordance with the TRUNK TYPE or the SLC® TYPE. Refer to 2.4.1 and 2.4.2

0/0 through X/1: defines bit patterns for specialized signaling used in some equipment that may be tested.

2.4 TRUNK CONFIG

This menu selects the trunk type that is emulated or monitored. It also sets the type of voice channel that is monitored if the framing (see 2.3.2) has been set for SLC®96 I or SLC®96 II. Finally it sets the E & M type if E & M 2W or E & M 4W have been selected as TRUNK TYPE.

TRUNK :	TRUNK TYPE	SLC®TYPE	E & M TYPE
CONFIG :	E & M 4W	SINGLE PARTY	I

Alternate:	E & M 2W	UNIVERSAL V G	II
	DID		III
	SF		IV
	loop		V
	ground		

2.4.1 TRUNK TYPE: The AM8a can be configured to interface with the types indicated by the alternates shown in the menu. The types may be either direct analog or a voice channel selected from a PCM link.

loop: This is the simplest type of interface. The terminal seizes a line by closing the loop. If analog has been selected (see 2.2.2) the equipment is connected to the LOOP T/R jack on the front panel. If PCM has been selected, the conditions are internally emulated/monitored on a selected voice CHANNEL.

ground: In ground start, the terminal seizes a line by grounding the tip lead. If analog has been selected (see 2.2.2), the equipment is also connected to the LOOP T/R jack on the front panel. If PCM has been selected, the conditions are internally emulated/monitored on a selected voice CHANNEL.

E & M 2W and E & M 4W: Refer to 2.4.3 for more information.

DID: This configuration is the same as LOOP except the switch initiates the seize and dialing signals.

SF: This is a four-wire (TX and RX) configuration in which signaling and dialing is by pulsed 2600 Hz tones.

2.4.2 SLC®TYPE: This selection is only active when FRAMING of SLC®96 I or SLC®96 II has been selected (see 2.3.2) and is only for monitor mode.

SINGLE PARTY: must be used with TRUNK TYPE loop.

UNIVERSAL VOICE GRADE: can be loop or ground start.

2.4.3 E & M TYPE: This selection is only active when TRUNK TYPE of E & M 2W or E & M 4W have been selected. The table below summarizes the connections that must be made to the equipment for the TYPE parameters selected if in analog mode. For PCM modes, the signaling bits will convey information:

E & M TRUNK INPUT Jack Signals	E & M TYPE				
	I	II	III	IV	V
E te/line orig.	x	x		x	x
M switch orig.	x	x	x	x	x
SB signal battery	-	x	x	x	-
SG signal ground	-	x	x	x	-
TX	TRUNK TYPE E & M 2W and 4W E & M 4W				
RX					

2.5 DISPLAY CONFIG 1 AND CONFIG 2

These menus control the AM8a LCD display and equivalent printouts. They allow the user to set the display to respond to calls, dialing events, SLC® messages, and single-tone events.

DISPLAY:	MODE	DIG DET	SLC®MSG
CONFIG1 :	new call reset	narrow	000000001

Alternate:	manual reset scroll	wide limit	000000000 to 111111111
-------------------	--------------------------------	-----------------------	-----------------------------------

DISPLAY:	T/t MASK
CONFIG2 :	NO

Alternate:	YES
-------------------	------------

2.5.1 MODE: This parameter controls how the events display will be updated.

new call reset: This selection will reset the display each time a new call is encountered. Events will enter the display buffer until it is full (80 characters max). After it is full, further events will be ignored until a new call is encountered.

NOTE: 40 characters will be displayed on the screen, while the remaining 40 characters are kept in the buffer until selected for viewing via the keys.

manual reset: This selection will display events until the 80 character buffer is full. All events after this will be ignored until the display is cleared by pressing the [SHIFT] [CANCEL] keys.

NOTE: In monitor mode for PCM, with channel number of 0 (random select) specified, the [SHIFT][CANCEL] keys will immediately abort monitoring of the current call so that the AM8a can monitor the next new call.
--

scroll: This selection will allow the most recent 80 events to be displayed as they occur. Old events will scroll off the display and be discarded as new events replace them. The FREEZE function is useful here to "stop" the display to analyze specific events.

2.5.2 DIGit DETection: This selection defines the way in which the AM8a will display or print dialed-digit events. These events may be pulse, DTMF, or MF(R1). Refer to DIALING EMULATE: LOOP TYPE (§3.3.1).

NOTE: MF(R1) digits will not be seen if DIALTONE is used as a Start Signal.

narrow: only dialed digits that are exceptions to the expected values, or are good will result in a displayed/printed message.

wide: all dialed digits, including those that are unrecognizable, will result in a displayed/printed message.

limit: only dialed digits that are good will result in a displayed/printed message.

2.5.3 SLC® MSG: This parameter allows the user to set a combination of 10 "flags" that direct the unit to respond to various conditions in a monitored Mode II SLC®% channel.

Use the ◀FIELD▶ keys to move to the flag. Use the 0 and 1 keys to set the flag. When the flag is set to "1" the condition will result in a message. If set to "0", the condition will be ignored.

The messages are identified by EVENT display codes (refer to 1.2.2) and DETAIL messages; both are listed below (actual message text will vary to fit second line of display):

SLC MSG		x=1 Message Detect active x=0 No Message Detect active	
x x x x x x x x x x	Event Code	Message	
	i	Trunk Assignment LDS to RT	
	y	Trunk De-assignment LDS to RT	
	j	Assignment Update LDS to RT	
	c or k	Looping Test	
	l	Activity Update Request LDS to RT	
	e or m	Idle/Trunk De-assignment update (E & M)	
	a	Activity RT to LDS	
	b	Activity Update RT to LDS	
	d	Assignment Update Request RT to LDS	
	f	No Alarm RT to LDS	
	n	COT Trunk Deassignment	
	no flag (always active)		

2.5.4 SLC® Activity Message: When the message detect active for the a or b events (shown in ¶2.5.3) is set, the activity messages in the 4Kbps data link can be monitored when CHANNEL is set to -97 (refer to 2.3.4). The chart that follows decodes the messages to identify the Line Group and the Active Channel(s) in the line group.

```

a 01:50.588 RT Activity      LG=n X X X X X X X X
b 01:50.588 RT Act Update   LG=n X X X X X X X X
    
```

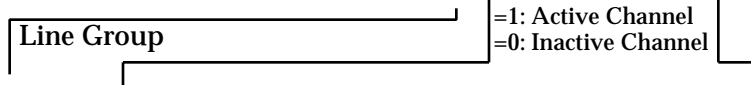

1	13	37	2	26	14	38	3	27
2	15	39	4	28	16	40	5	29
3	17	41	6	30	18	42	7	31
4	19	43	8	32	20	44	9	33
5	21	45	10	34	22	46	11	35
6	23	47	12	36	24	48	1	25

2.5.5 T/t Mask (single-tone event selection): This selection, on the second CONFIG menu controls the display of single-tone events. When YES has been selected, all single-tone events will be masked (not displayed). When NO has been selected, single tone events are not masked (displayed).

2.6 RS232 CONFIG

This menu is used to configure the AM8a RS232 port. The settings can only be changed by operator entry.

RS232	:	BAUD RATE	PARITY	CR DELAYsec
CONFIG:		9600	none	0

Alternate: **300** **odd** **0 to 99 (1sec steps)**
 1200 **even**
 2400

2.6.1 BAUD RATE: This selects the baud rate of the RS 232 port. Available baud rates are shown by the alternates listed above.

CAUTION: *When units are chained, set all parameters the same on each unit, and do not exceed 2400 baud.*

- 2.6.2 PARITY:** This will select whether Even or Odd parity will be used for error checking. This will also allow for NO parity check to be used.
- 2.6.3 CR DELAYsec:** Carriage Return Delay. This parameter allows a delay to be inserted after a carriage return is sent at the end of a line of text. This delay will prevent further characters being sent during the time required for the carriage return in a printer without a built-in buffer.

NOTE: The RS232 serial date will have the format of 1 stop bit and 7 data bits when parity is enabled. When parity is disabled, 8 data bits will be used.

2.7 SECURITY CONFIG

The two security settings can only be changed by operator entry.

SECURITY:	PASSWORD	SETUP PROTECT
CONFIG :	no	yes

Alternate:	yes	no
-------------------	------------	-----------

- 2.7.1 PASSWORD:** is used for RS232 security. If PASSWORD is enabled ("yes"), unauthorized access to the unit can be prevented. Access must be gained via a "Logon" procedure. See the RS232 Entries and printouts in section 7 to set or change passwords.
- 2.7.2 SETUP PROTECT:** Setup allows the stored configuration to be protected from accidental modification. When "yes" is selected and a STORE is attempted, the display will indicate that Setup Protect is enabled; the STORE command will be ignored. To STORE setups, set this parameter to "no".

NOTE: When Setup is PROTECTED, previously stored setups may be recalled as normal. Also, parameters may be changed via the front panel controls or RS232 commands.

2.8 PRINT CONFIG

This menu selects what information will be printed when the automatic print mode has been enabled.

PRINT :	AUTOPRINT
CONFIG:	off

Alternate:

- all calls,events only**
- all calls,events & details**
- flawed calls,events only**
- flawed calls,events & details**

- 2.8.1 off:** This selection AM8a will not automatically print the events and/or details that have been analyzed.
- 2.8.2 all calls, events only:** This selection will cause the AM8a to automatically print the events it has analyzed. The printout will be output at the start of the next call sequence. The printout will consist of the events of the call without any details.
- 2.8.3 all calls, events & details:** This selection will cause the AM8a to automatically print the events and details it has analyzed. The printout will be output at the start of the next call sequence.
- 2.8.4 flawed calls, events only:** This selection will cause the AM8a to printout the analyzed events when a call sequence is outside the tolerance specified in the ANALYZE setup menus. The printout will be output at the start of the next call sequence and will print only the events of the call.
- 2.8.5 flawed calls, events & details:** This selection will cause the AM8a to printout the analyzed events and details when a call sequence is outside the tolerance specified in the ANALYZE setup menus. The printout will be output at the start of the next call sequence.

2.9 CLOCK CONFIG

This menu is used to set the Real Time Clock and Date which appears in the Events Display as well as on reports generated via the RS232 port. These parameters can only be changed by operator input. The factory default clock setting is shown below ("X"s are not part of display):

CLOCK :	DATE(MM/DD/YY)	TIME(HH/MM)
CONFIG:	XXX1 XXX1 XX91	XX12 XXX1

Alternate: 1-12 1-31 0-99 0-23 0-59

NOTE: As entries into date and time fields are made, leading zeroes (0) are displayed where "X"s are shown. Leading 0s are cleared when the next field is selected. This is typical of most displays which require entry of numeric data.

2.10 AM8a CONFIG

The VERSION menu contains information only. It is not programmable. The CPU field shows the firmware version used for the main control of the AM8a. The DSP0 and DSP1 fields indicate the DSP firmware used for audio processing functions such as tone generation and measurements. The display below is to illustrate format; the actual numbers displayed may be different.

AM8a :	CPU	DSP0	DSP1
CONFIG:	105	100	100

3. EMULATE PARAMETERS

The EMULATE parameters are used to define the values and timing of the events initiated by the AM8a. These parameters are only used when the Te/Line or Switch is set to CONFIG "MODE emulate". When set to "MODE monitor" they are not used, and also cannot be printed at a terminal.

3.1 LOOP EMULATE

This menu is used to setup the characteristics of the interface when configured as an analog LOOP START TRUNK TYPE.

LOOP	:	VOLTAGEvdc	LENGTHohm
		48	1200

Alternate: **20 to 72** **0 to 2100(300ohm steps)**

3.1.1 VOLTAGE: This is the battery voltage that will be supplied by the AM8a when configured to emulate an analog switch (refer to 2.1 and 2.2).

3.1.2 LENGTH: This parameter allows the selection of the loop length to be simulated by the AM8a.

3.2 TERMINATION EMULATE

This menu controls the termination for the analog signals on the trunk.

TERMINATION:	2.16uf	DC HOLD
EMULATE	:	in
		330ohm

Alternate: **out** **10ohm**
430ohm

3.2.1 2.16uf: 2.16 microfarads is a standard capacitive component of the termination impedance when set to IN.

out: the capacitance is increased to 24uf so that it has little or no effect on the termination for audio frequencies from 200Hz to 3400 Hz.

3.2.2 DC HOLD: This parameter controls the DC holding resistance placed across Tip and Ring during an OFF-HOOK condition.

3.3 DIALING EMULATE

This menu controls the dialing type and the signal used as a start dial indication.

DIALING :	LOOP TYPE	START SIGNAL
EMULATE:	pulse	wink
Alternate:	dtmf mf(R1)	Immediate delay dial tone

3.3.1 LOOP TYPE: This selects the dialing type the AM8a will out-pulse. This dialing type may be changed using the "TOGGLE DIAL" key (or equivalent character in an AUTO DIAL sequence).

3.3.2 START SIGNAL: This is the START SIGNAL provided by the AM8a when the START key is pressed or the AM8a is in the AUTO mode and an OFF HOOK is detected.

3.4 PULSE EMULATE

The PULSE dialing specifications are programmed in this menu. These parameters are used when the AM8a LOOP TYPE parameter is set to PULSE in the DIALING menu.

PULSE :	SPEEDpps	BREAK%	INTRDIGITms
EMULATE:	10	60	600
Alternate:	5 to 25	40 to 85	120 to 999

3.4.1 SPEEDpps: This controls the number of pulses per second for each digit out-pulsed.

3.4.2 BREAK%: This controls the % of break (open loop) of each pulse making up a out-pulsed digit.

3.4.3 INTRDIGITms: The Inter-Digit Time is programmed here. This is the amount of time from the last pulse of the previous digit until the first pulse of the next digit.

3.5 DTMF/MF EMULATE 1

The Tone dialing specifications are programmed in this menu. These parameters are used when the AM8a LOOP TYPE parameter is set to DTMF or MF in the DIALING menu. DTMF and MF dialing use two tones of fixed frequencies (one a low band, the other a high band) generated simultaneously. This menu allows the user to apply "TWIST" and/or "SKEW" to the out-pulsed digits.

DTMF/MF :	HI: dBm/hz%	LO: dBm/hz%
EMULATE 1:	-7 -0.0	-7 -0.0

Alternate: **dBm = -40 to -3 (1dB steps)**
 Hz = -5.0 to +5.0 (0.1 % steps)

3.5.1 HI:dBm/hz%: This controls the level and frequency of the HI band tone of a tone dialed digit.

3.5.2 LO:dBm/hz%: This controls the level and frequency of the LO band tone of a tone dialed digit.

3.6 DTMF/MF EMULATE 2

Additional Tone dialing specifications are programmed in this menu. These parameters are used when the AM8a LOOP TYPE parameter is set to DTMF or MF in the DIALING menu.

DTMF/MF :	ON/OFFms
EMULATE 2:	50 50

Alternate: **25 to 99 (1ms steps)**

3.6.1 ON/OFFms: ON time is the amount of time the tones are sent for each digit out-pulsed. OFF time is the amount of quiet (OFF) time between digits.

NOTE: This parameter is only effective when AUTO DIAL dialing is used. For manual dialing, the ON time depends on how long the digit key is pressed, and the OFF time is the interval between the pressing of two successive digits.

3.7 SEND TONE EMULATE

This menu allows the user to program the level and frequency of a single test tone which may be sent from the AM8a when the SEND TONE key is pressed.

SEND TONE:	LEVELdBm	FREQUENCYhz
EMULATE :	-10	1004

Alternate: **-40 to 0 (1dB steps) 300 to 3300 (1hz steps)**

3.7.1 LEVELdBm: This controls the level of the single test tone.

3.7.2 FREQUENCYhz: This controls the frequency of the single test tone.

3.8 DIAL TONE EMULATE 1

This parameter allows a Dial Tone Cadence to be programmed. If all the OFF times are set for 0000, and only one ON time is set to 9999, a continuous Dial Tone will be sent if Dial Tone is selected as the START SIGNAL.

DIAL TONE:	ON/OFFms	ON/OFFms	ON/OFFms	ON/OFFms
EMULATE 1:	9999	0	0	0

Alternate: **0 to 9999 (1ms steps)**

Programming an OFF time will provide interrupted dial tone. The additional ON/OFF parameters will only be used if the first OFF time is given a value greater than zero. Use of these parameters will provide a dial-tone cadence like "one long, two short".

3.9 DIAL TONE EMULATE 2

The Dial Tone provided by the AM8a when seized by the Calling Party (and DIALING: START SIGNAL is set to dial tone) may be programmed here. The dial tone consists of two tones generated simultaneously. The LEVEL and FREQUENCY of each tone can be varied independently.

DIAL TONE :	T1:dBm/hz	T2:dBm/hz	DL SNDms
EMULATE 2 :	-13 350	-13 440	250

Alternate: dBm = -40 to -3 (1dB steps) 15 to 9999 (1ms steps)
Hz = 0 or 300 to 3300 (1 hz steps)

- 3.9.1 T1:dBm/hz:** This parameter controls the level and frequency of the first tone of the composite dial tone signal.
- 3.9.2 T2:dBm/hz:** This parameter controls the level and frequency of the second tone of the composite dial tone signal.
- 3.9.3 DL SNDms:** This parameter is a delay time from seizure to providing the dial tone when the AM8a is set to AUTOMATIC.

3.10 RECALL EMULATE

This menu is used for special calling features such as Call Transfer, Conference Calling, etc.

RECALL :	HOOKFLASHms	LINE UNBALms
EMULATE:	500	500

| Alternate: 15 to 999 (1ms steps) 15 to 9999 (1ms steps)

- 3.10.1 HOOKFLASHms:** This is the duration of a Hook Flash generated by the AM8a.
- 3.10.2 LINE UNBALms:** This is the International version of FLASH. The timing is utilized the same way as flash. The difference is that an unbalance will apply a ground on the ring lead for the programmed time.

3.11 RINGING EMULATE 1

This menu controls the ringing Cadence applied to the line during ring.

RINGING	:	ON/OFFms	ON/OFFms	ON/OFFms
EMULATE 1:		2000 4000	0 0	0 0

Alternate: **on = 0 to 5000 (1ms steps)**
 off = 0 to 9999 (1ms steps)

- 3.11.1 ON/OFFms:** Two additional parameters may be used for custom ring cadence programming. They allow for programming a sequence of cadences to simulate custom calling features such as callback queuing or auto call back.

NOTE: If Ringing ON time plus OFF time exceeds 10 seconds, a New Call Reset will occur.

3.12 RINGING EMULATE 2

RINGING	:	VOLTAGEvrms	FREQUENCYhz
EMULATE 2:		85	20.0

Alternate: **30 to 105 (5v steps)** **15 to 70 (0.1hz steps)**

- 3.12.1 VOLTAGEvrms:** This parameter controls the RMS voltage that is applied during the ring cycle.
- 3.12.2 FREQUENCYhz:** This parameter controls the frequency of the ringing applied during the ring cycle.

3.13 START TIME EMULATE

These parameters are used for programming the timing of the DELAY and WINK START SIGNALS.

START TIME:	DLY:BGN/ENDms	WINK:BGN/DURms
EMULATE :	100 250	100 250

Alternate: BGN = 15 to 999 (1ms steps) BGN = 15 to 999 (1ms steps)
 END = 100 to 9999 (1ms steps) DUR = 50 to 999 (1ms steps)

3.13.1 DLY:BGN/ENDms: This setting controls the DeLaY BeGiN timing. This is the time from seizure until the DELAY START DIAL signal is sent. The AM8a must be set to EMULATE and have the AUTOMATIC selection made. The END time is when the DeLaY signal will be removed.

3.13.2 WINK:BGN/DURms: This setting controls the wink BeGiN timing. This is the time from seizure until the WINK is sent. The AM8a must be set to EMULATE and have the AUTOMATIC selection made. The DURation controls how long the wink is on the line.

3.14 SF EMULATE

This menu sets the level and frequency variation of the Single-Frequency (2600Hz) signal that is used for signaling when the TRUNK TYPE is SF (Refer to 2.4.1).

SF	:	LEVELdBm	FREQ + %hz
EMULATE	:	-10	0.0

Alternate: -40 to 0 (1 dBm steps) -2 to 2 (.1 % steps)

3.14.1 LEVEL: sets the 2600Hz SF tone from -40 dBm to 0 dBm.

3.14.2 FREQ+%hz: sets the frequency variation of the 2600Hz SF tone from -2% to +2% in .1 % steps (2548Hz through 2652Hz).

Emulation Parameters

(18-0037)

AM8a Instruction Manual

4. ANALYSIS PARAMETERS

The menus described in this section are used to set parameters which the AM8a uses for interpreting expected events as well as analyzing the events that occur during a call sequence.

The parameters provide lower and upper ranges or single-value thresholds for event recognition and for flagging failures of specific events. To use these menus, the operator must first select the ANALYZE Setup menu. The parameters are then set as menus are displayed.

During tests, if an event falls outside of the programmed range, the display will indicate this failure by flashing the analysis line of the Events Display; when the ">" character is selected for analysis, the detail line will flash to indicate that an Event in the call sequence failed.

The user may then move the cursor to find the specific Event which failed. Once the failed Event has been selected, the specific detail which failed will flash. An RS232 report will flag an out-of-spec. event with an "*".

4.1 HOOK ANALYZE

This menu controls how the AM8a interprets "ON HOOK" conditions. This applies to all TRUNK TYPES that can be selected in the CONFIG SETUP menu. See 4.11.2 for OFF HOOK information if ANALOG(loop) is used.

HOOK	: FLASHms(min)	DISCONNECTms(min)
ANALYZE:	450	1000

Alternate: 50 to 1250 (1ms steps) 50 to 1250 (1ms steps)

4.1.1 FLASHms(min): An "ON HOOK" greater than the FLASH timing but less than the DISCONNECT time is considered a hook flash.

An "ON HOOK" duration less than the FLASH time is considered to be a dial pulse digit.

4.1.2 DISCONNECTms(min): If the duration of an "ON HOOK" signal exceeds this parameter, the AM8a assumes a true disconnect has occurred and will interpret the next "OFF HOOK" as the beginning of a new call..

4.2 STRT SIG (START SIGNAL) ANALYZE: EXPECTED TYPE

This menu is used to set the Start Signal EXPECTED by the AM8a when it is the calling party (originator of the call). Dialtone will always be accepted, and the additional choices that can be recognized are either wink or delay start.

STRT SIG :	EXPECTED TYPE
ANALYZE:	dialtone/wink

Alternate: dialtone/delay

- 4.2.1 dialtone/wink:** This instructs the AM8a to EXPECT dialtone **OR** a wink as the Start Dial. If a wink is received in less than 999 ms, the Events display will show a "W". If the wink is not received within 999 ms, the Events display will show a "Pp". Within the 999 ms, error reporting will depend on the parameters in the WINK STRT menu.
- 4.2.2 dialtone/delay:** This instructs the AM8a to EXPECT dialtone **OR** a delay dial signal. When the delay dial signal is received, the Events display will show a "Pp". Error reporting will depend on the parameters in the DLY STRT menu.
- 4.2.3 dialtone/...:** Dialtone will always be accepted as a start signal. If a dialtone is received, an "X" will be displayed and error reporting will depend on the parameters in the DT STRT menu.

4.3 DT STRT (DIALTONE START) ANALYZE: DIALTONE RCVDms (min/max)

This menu selects the DIALTONE RECEIVE timing. If dialtone is received as a Start Signal, it must arrive within this threshold to be valid. If received outside of these limits, it will be flagged as an error.

DT STRT :	DIALTONE RCVDms(min/max)
ANALYZE:	0 3000

Alternate: 0 to 9999 (1ms steps)

4.4 DLY STRT (DELAY START) ANALYZE

When the EXPECTED TYPE of Start Signal is set to dialtone/delay, these parameters control what is reported as an exception. If dialtone is received, these settings are not used.

DLY STRT:	STRT BGNms(min/max)	ENDms(min)
ANALYZE:	0 300	140

Alternate: **0 to 999 (1ms steps) 0 to 9999 (1ms steps)**

4.4.1 STRT BGNms(min/max): This is the time from off hook to the DELAY dial START SIGNAL. If the timing is outside the range, it is flagged as an exception.

4.4.2 ENDms(min): This time must be exceeded in order for the delay signal to be valid. A delay signal shorter than this time will be flagged as an exception.

4.5 WINK STRT

When the EXPECTED TYPE of Start Signal is set to dialtone/wink, these parameters control what is reported as an exception. If dialtone is received, these settings are not used.

WINK STRT:	WINK BGNms(min)	DURms(min/max)
ANALYZE :	15	140 290

Alternate: **15 to 999 (1ms steps) 50 to 999 (1ms steps)**

4.5.1 WINK BGNms(min): This is the time from off hook to the WINK START SIGNAL. If the timing exceeds this parameter, it is flagged as an exception.

4.5.2 DURms(min/max): This is the time the wink signal must be present to be valid. A wink signal less than the minimum (min) time or greater than the maximum (max) time of this setting will be reported as an exception.

4.6 PULSE ANALYZE 1

This is the first of two menus used for PULSE dial analysis. This menu contains parameters for the speed and percent of break time analysis.

PULSE	:	SPEEDpps(min/max)	BREAK%
ANALYZE 1:		8.0 12.0	50 70

Alternate: **5 to 25 (0.1pps steps) 20 to 85 (1% steps)**

NOTE: The OFF HOOK vdc parameter described in 4.11.2 will also affect the ability to detect PULSE dial digits.

- 4.6.1 SPEEDpps(min/max):** When pulse dialing is received, the SPEED (pulses per second) must fall within the min and max range programmed here. If the SPEED falls outside this range, the Event is flagged as an error.
- 4.6.2 BREAK%:** When pulse dialing is received, the BREAK % must fall within the min and max range programmed here. If the % BREAK falls outside this range, the Event is flagged as an error.

4.7 PULSE ANALYZE 2

This is the second of two menus used for PULSE dial analysis. This menu contains parameters for the interdigit time analysis.

PULSE	:	INTRDIGITms(min)
ANALYZE 2:		300

Alternate: **120 to 999 (1ms steps)**

- 4.7.1 INTERDIGITms(min):** When PULSE dialing is received, the INTERDIGIT time must fall within this parameter. If the time falls outside this range, the Event is flagged as an error.

4.8 DTMF/MF ANALYZE 1

This is the first of three menus used for Tone dialing analysis. These menus apply to DTMF, MF(R1), and MF(R2). This menu contains the parameters used to set the Low Band and Hi Band thresholds.

NOTE: MF(R1) digits will not be seen if DIALTONE is used as a Start Signal.

DTMF/MF	:LO BANDdB(min/max)	HI BANDdB
ANALYZE 1:	-15 -3	-15 -3

Alternate: **-30 to -3 (1dB steps) -30 to -3 (1dB steps)**

4.8.1 LO BANDdB(min/max): When Tone Dialing is received, the Lo Band LEVEL must fall within the min and max settings of this parameter to be valid. If the Level is outside of the programmed range, the Event is flagged as an error.

4.8.2 HI BANDdB: When Tone Dialing is received, the Hi Band LEVEL must fall within the min and max settings of this parameter to be valid. If the Level is outside of the programmed range, the Event is flagged as an error.

4.9 DTMF/MF ANALYZE 2

This is the second of three menus used for Tone dialing analysis. These menus apply to DTMF, and MF(R1) frequencies. This menu contains the parameters used to set the Frequency offset and Twist thresholds. For information on tone frequencies, refer to the description and tables on the next page.

NOTE: MF(R1) digits will not be seen if DIALTONE is used as a Start Signal.

DTMF/MF	: FREQ%(max)	TWISTdB(min/max)
ANALYZE 2:	1.5	-6 6

Alternate: **0 to 3.5 (0.1% steps) -12 to +12 (1dB steps)**

- 4.9.1** **FREQ%(max):** When Tone Dialing is received, the Frequency of the Lo Band and the Hi Band must not deviate more than this setting from the nominal Frequency. If the percent of deviation (\pm) exceeds this setting, the Event is flagged as an error.
- 4.9.2** **TWISTdB(min/max):** When Tone Dialing is received, the difference (Twist) between the Lo Band Level and the Hi Band Level of a digit must not exceed the range of this parameter to be valid. If the difference exceeds this range, the Event is flagged as an error.
- 4.9.3** **DTMF Frequencies:** There are 16 frequency combinations that represent the DTMF (dual-tone multi-frequency, also referred to as "touch-tone®") digits that can be used. 1 - 9, *, 0, and # appear on a standard touch-tone dial (4 x 3 matrix).

The A, B, C, and D digits are used for inter-office dialing and other special applications and may appear on some special-purpose dials (such as is used on the AM8a Program Keyboard and the example below). The frequencies can be determined from the figure below:

DTMF FREQUENCIES					
HIGH BAND FREQUENCY					
1209	1336	1477	1633		
1	2	3	A	697	L O W B A N D F R E Q U E N C Y
4	5	6	B	770	
7	8	9	C	852	
*	0	#	D	941	

Example: DTMF digit 5 is made up of two frequencies. Reading to the right for Low Band gives 770 Hz. Reading up for High Band gives 1336 Hz.

4.9.4 MF(R1) Frequencies: There are 15 frequency combinations that represent the possible MF (Multi-Frequency) tones that are used between Central Offices and some PBXs. For the AM8a to analyze digits as MF, a KP digit must immediately precede the first dialed digit.

NOTE: MF(R1) digits will not be seen if DIALTONE is used as a Start Signal.

The analyzing of digits as MF will cease with the reception of an ST, ST3P, STP, or ST2P digit. Refer to the table on the next page.

NOTE: The KP digit ON-time is twice the programmed value.

Example: MF digit 5 is made up of two frequencies: Low Band 900 Hz and High Band 1300 Hz.

MF FREQUENCIES

DIGIT	LO BAND	HIGH BAND
1	700	900
2	700	1100
3	900	1100
4	700	1300
5	900	1300
6	1100	1300
7	700	1500
8	900	1500
9	1100	1500
0	1300	1500
* (KP)	1100	1700
# (ST)	1500	1700
A (ST3P)	700	1700
B (STP)	900	1700
C (ST2P)	1300	1700

4.10 DTMF/MF ANALYZE 3

This is the third of three menus used for Tone dialing analysis. These menus apply to DTMF, and MF(R1). This menu contains parameters used to set Tone ON and OFF time thresholds and Guard Time.

DTMF/MF :TONE ON/OFFms(min)	GUARDms
ANALYZE 3: 35 35	40

Alternate: * 25 to 99 (1ms steps) 0 to 99 (1ms steps)

* min ON time setting for DTMF = 25 ms

* min ON time setting for MF(R1) = 35 ms

4.10.1 TONE ON/OFFms(min): When Tone Dialing is received, the ON time (time the digit is present) and OFF time (quiet time between digits) must be greater than the setting of these values. If either the ON time or the OFF time exceed these settings, the Event is flagged as an error.

4.10.2 GUARDms: When a Tone is present, this parameter controls whether or not the AM8a will analyze it. This GUARD (Tone ON time) time **MUST** be exceeded before the AM8a will analyze it. If the Event is shorter, it will be ignored.

4.11 THRESHOLD ANALYZE

This menu controls the Tone Level and the Off Hook threshold that the AM8a will recognize.

THRESHOLD: TONEdBm(min)	OFF HKvdc(min)
ANALYZE : -30	35

Alternate: -40 to 0 (1 dB steps) 2 to 60 (1 vdc steps)

4.11.1 TONEdBm(min): When a Tone is present, this parameter determines the LEVEL which must be exceeded before the AM8a will analyze it. If a Tones Level is below this setting, the AM8a will ignore it.

4.11.2 OFF HKvdc(min): This parameter sets the threshold the AM8a uses to determine OFF HOOK status when it is configured to ANALOG(loop). The dc voltage present across the Tip and Ring leads must fall below this threshold (towards zero, regardless of polarity) before the AM8a will recognize an OFF HOOK condition. This threshold will also affect the ability of the AM8a to detect dial PULSE digits. The next sub-section provides the procedure to determine the best setting of this parameter.

4.11.3 Procedure to Set OFF HKvdc(min) Threshold: The on/off hook threshold **TO** voltage must be carefully set to ensure the AM8a correctly recognizes ON and OFF hook events. The setting may have an effect on the operation of the PULSE digit analyzer, since PULSE dialing is accomplished by opening and closing of the loop. (ON/OFF-HOOK).

A quick way to determine the setting of what voltage to set the threshold voltage is to use the METER DISPLAY as follows (refer to sub-section 6.4):

1. When the LINE/TERM equipment is ON HOOK, measure the V_{t-r} dc. This voltage should be equivalent to the battery supply of the switching equipment.
2. Go OFF HOOK with the LINE/TERM equipment and again measure the V_{t-r} dc. This voltage will indicate the OFF HOOK voltage and should be the minimum voltage encountered under normal operation.
3. Now set the OFF HK vdc(min) parameter for a voltage between the two measured voltages.

Analysis Parameters

(18-0037)

AM8a Instruction Manual

5. AUTO AND MANUAL DIALING

The AUTODIAL display provides a way for the operator to store ten dialed-number sequences, each with a maximum of 60 characters. The Autodial is active when the AUTO mode has been selected, [SHIFT then **VALUE**]. If AUTO has not been selected, all dialing will be Manual.

5.1 STORE AUTODIAL SEQUENCE

To store a dialing sequence in the Auto Dial:

1. Press [SHIFT] then [AUTO DIAL]. The display will indicate "AUTO DIAL MENU x" with a digit (0-9) flashing. The example below shows MENU 1 with all possible characters entered (30 characters per line; 60 characters maximum).
2. Use the **▼ MENU ▲** keys to select the desired MENU (0 - 9 or *) to enter the number you would like to have dialed automatically.
3. Enter dialed digits with the keys [1] through [9], [0], [*], [KP], [#], [ST], and red-labeled keys (requiring SHIFT-SHIFT) [A], [B], [C], or [D], depending on the dialing mode to be used, for the number you will later dial.

Digits will be displayed as entered, from left to right. For editing an existing number, use the **◀FIELD▶** keys to move to a specific digit, and enter the new digit (over the existing one).

4. Special Autodial functions (such as WAIT DT, WAIT WINK, etc.) also shown in Red under the input keys may be entered. These functions are summarized in the table on the next page. Refer to 4.9.3 and 4.9.4 for the frequencies for the DTMF and MF (R1) tones.
5. After completing step 3 and/or 4, exit the Autodial Setup by selecting a different SETUP, or display EVENTS or METER.

Special Auto-Dial Functions

Auto Dial Character	SHIFT-SHIFT (Red LED)	AM8a Function
P	1	WAIT DT (Wait for Dial-Tone)
W	2	WAIT WINK
-	3	WAIT (for 3 seconds)
F	4	FLASH
U	5	UNBALance (line)
T	6	TOGGLE DIAL (TT, MF, DP, TT . . .)
SPACE	7	BLANK

5.2 SELECT AND USE AUTO DIAL SEQUENCE

1. The last Auto dial menu shown in the display determines the dialing sequence to be used when dialing conditions are met (see 2). If desired, you may first recall a stored number by pressing [SHIFT] [RECALL] [(location)]. "Location" may be 0 through 9 for a previously stored sequence, or "*" to recall the last number dialed.
2. Select the EVENTS display mode.
3. Press SEIZE to go OFF HOOK.
4. If the AM8a is in AUTO mode, the selected sequence is automatically dialed when dialtone or the EXPECTED TYPE Start Signal is received.

NOTE: The AUTO ON/OFF time between DTMF or MF digits is set by the DTMF/MF, EMULATE 2 menu described in sub-section 3.6.1. The characteristics of pulse digits is set by the PULSE EMULATE menu described in sub-section 3.4.

5.3 MANUAL DIALING

1. If the AM8a is in EVENTS display, but not in AUTO mode, digits will be dialed as dialed-digit keys are pressed on the front panel. As the keys are pressed, the entered numbers will be stored in the last-number-dialed (*) location (replacing any digits from a previous dialing sequence). This number may be used later in an AUTO sequence, or in step 2, below.

NOTE: For DTMF or MF digits, the length of time a digit key is held determines the ON time; the interval between releasing one digit key and pressing the next digit key determines the OFF time between consecutive digits. For pulse-dial digits, pressing the digit key will cause the AM8a to output digits at SPEEDpps and BREAK% set by the PULSE EMULATE menu described in sub-section 3.4. Interdigit time may be longer than set by INTRDIGITms if the operator pauses between pressing keys .

2. A previously-stored number will be dialed when its location is RECALLED.

Auto and Manual Dialing

(18-0037)

AM8a Instruction Manual

6. METER DISPLAY

The Meter Display section of the AM8a eliminates the need for a separate Digital Volt Meter while testing a circuit. The Meter Display allows the user to make AC and DC voltage measurements, current measurements, and tone measurements. Idle-channel noise measurements can also be made. When using the AM8a in a PCM mode, the Meter Display will also give framing information and dBdsx levels.

6.1 MEASURE/SCALE MENU

After the DISPLAY METER key is pressed, the MEASURE/SCALE menu will be displayed first. (typical analog measuring scale shown; other selections, such as "Tx1 Vcm dc..." may be displayed):

MEASURE	SCALE	MEASURE	SCALE
Vt-r dc	100	Vr-g ac	5

This menu allows the user to select the measuring function of the meter. There are two MEASURE selections and two SCALE selections which are selected with the FIELD left or right arrow keys (◀FIELD▶). This allows DC and AC measurements to be made simultaneously.

- MEASURE allows the user to select the DC or AC measurements.
- SCALE allows the user to select the full scale range for the meter graph.

Refer to 6.3 for the details on the connections for the different MEASURE selections which are selected by pressing the MENU down or up keys (▼MENU▲). The next sub-section (6.2) describes making measurements after having set the MEASURE and SCALE parameters.

6.2 MEASURE DISPLAY (MAKING MEASUREMENTS)

The "INPUT" must be ON (SHIFT and [9]) in order to make valid measurements. Press the MENU up key to get the measure display. This display will have measurements appropriate to the Measure menu. A typical display for analog SCALE and MEASURE selections, that corresponds to the selection under 6.1, follows (other displays are shown under 6.4.6, and 6.7 through 6.11).

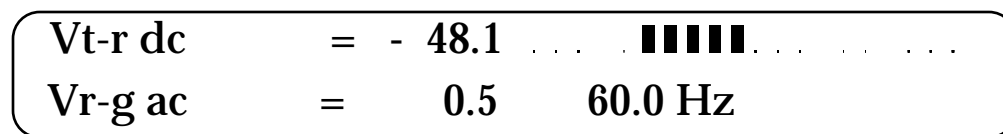

The mode and units of measure are indicated to the far left. The actual measured value is then displayed numerically as well as graphically. The DC graph's "0" point is in the center of the graph. For a negative measurement, the graph lies to the left. For positive measurements, the graph lies to the right. The SCALE should be set so the graph will obtain the best resolution based on the anticipated measurements.

6.3 METER SELECTIONS AND CONNECTIONS

Sub-sections 6.4 through 6.11 describe the different meter selections. The possible selections that can be used depend on the Trunk Type programmed in the CONFIG'N Setup menus which also determines which Front Panel jacks are active.

Figure 6-1 shows the cables that can be used to make measurements. Usually the 48-0062 cable(s) is used for Analog Measurements, while the 48-0047 and 48-0048 cables are used for PCM Measurements. The Bantam or PL310 plug may be plugged into jacks on a monitoring panel at a DSX.

NOTE: A 48-0131 (bantam to bantam) or 48-0157 (bantam to miniclip) Monitor Cable should be used for RX monitor connections to a DSX if the DSX monitor jacks are not provided with isolating resistors. These cables have internal resistors and their external appearance is similar to those shown in Figure 6-1, except for identifying label.

The 48-0047 cable(s) is also used to interconnect the AM8a with an AM5XT via the TMS TX/2W and RX jacks, for detailed measurements of circuit impairment. TMS connections are described and illustrated in a separate sub-section.

Figure 6-2 illustrates the measurements that can be taken when the clip leads are connected to CO circuits if a 48-0062 cable is connected to the LOOP jack illustrated at the top of the Figure. This figure is designed to provide a quick reference for the user connecting the clip leads on the cable to the appropriate circuits of a line or trunk. Figure 6-3 similarly shows the E & M/SS Connections.

NOTE: Color codes for clip leads on 48-0062 cables have been revised from previous issue to show cables manufactured after 7 May 1992. Further information on Figure 6-1.

Figure 6-4 shows the PCM1 and PCM 2 Connections. Because PCM connections at a CO are usually brought out to jacks for Bantam or 310 plugs, plugs are shown in this figure.

There are Pins on the rear panel DB-24F Connector, labeled LINE/TIMS, that correspond to the contacts on the front panel jacks. In Figures 6-2 through 6-4 these pin numbers are shown circled for ease of reference. There is also a rear panel binding post labeled CO GROUND in addition to the connections on the LINE/TIMS connector.

Rear-panel connections allow the user to "hard-wire" the AM8a into an exchange. The user must provide a cable wired to a matching DB 24M connector if the LINE/TIMS connector is to be used. A view of the rear panel (and connector pin identifications) is shown in Section 7.

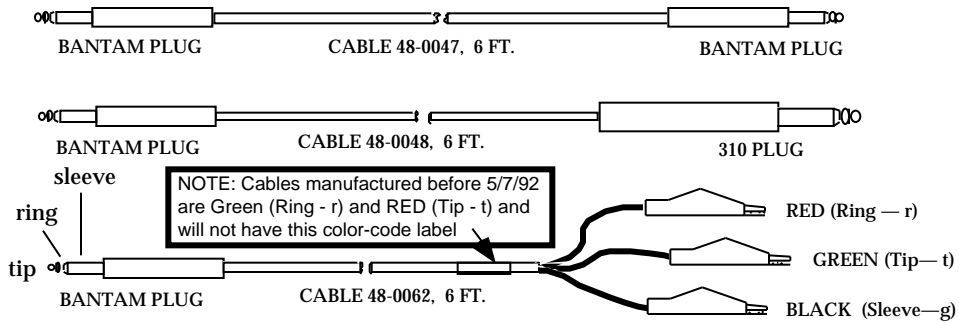

Figure 6-1. Cables for AM8a Front Panel Test/Meter Connections

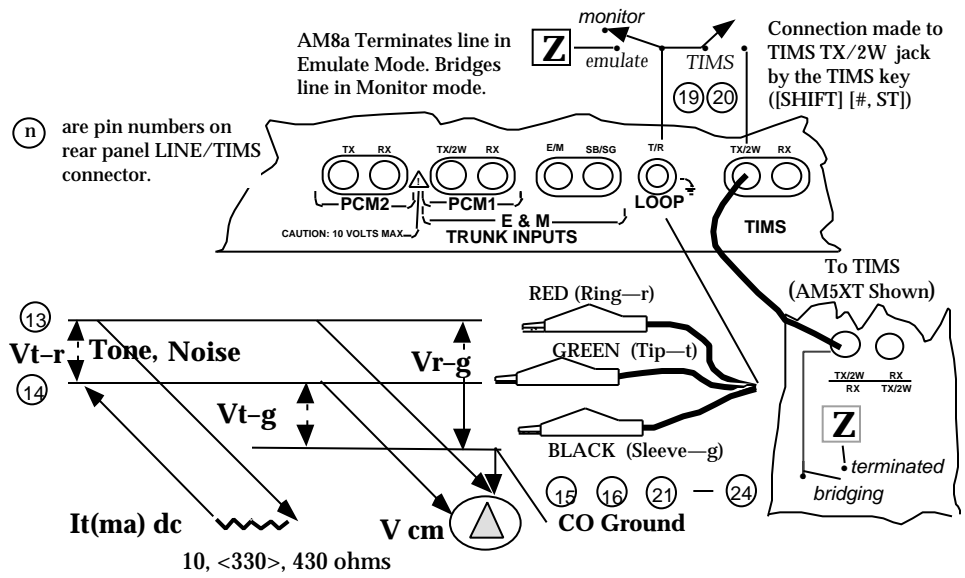

Figure 6-2. Loop/Ground Start and DID Analog Test/Meter Front Panel Connections

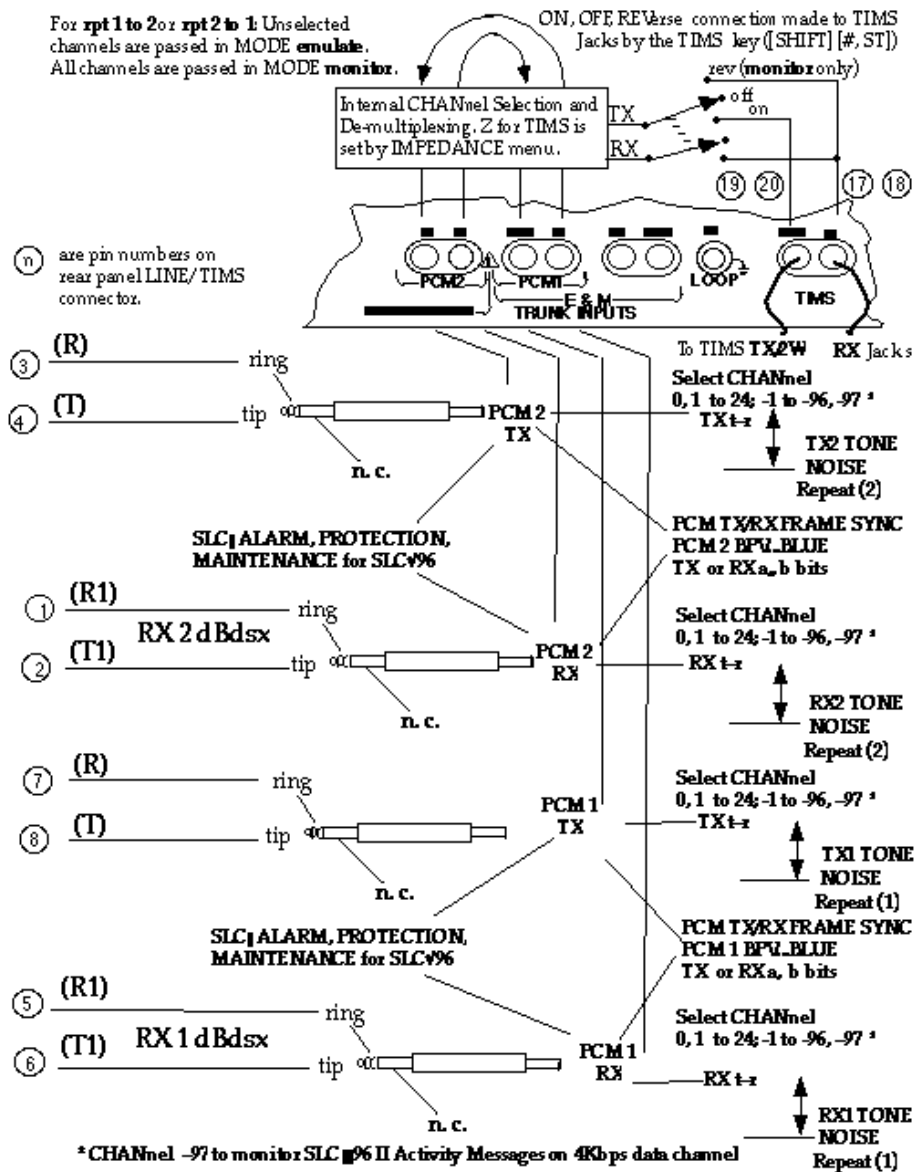

Figure 6-3. E & M and SF Test/Meter Front Panel Connections

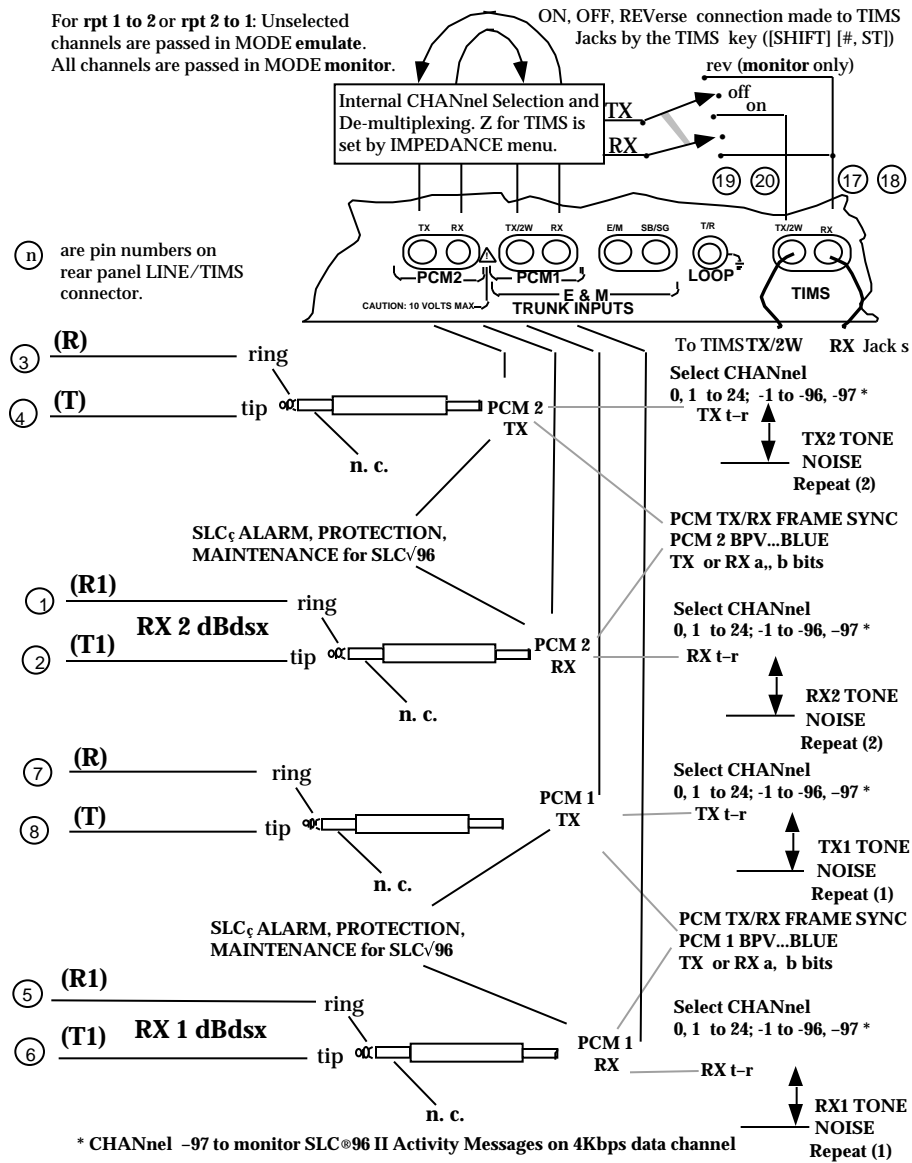

Figure 6-4. PCM T1/SLC[®]96 Test/Meter Front Panel Connections

6.4 LOOP START, GROUND START, DID – ANALOG MEASURE

The measurements described in sub-sections 6.4.1 through 6.4.6 are made at the LOOP jack on the front panel using a 48-0062 cable. The DC and AC MEASURE selections described are listed below in the order presented (beginning at top of left column) as the MENU up key is pressed:

		Tone		Description of Measurements
		ac	ac	tip-ring tone (dBm and Hz)
Vt-r	dc	Vt-r	ac	tip-ring voltage
Vcm	dc	Vcm	ac	tip & ring common mode
Vt-g	dc	Vt-g	ac	tip-ground voltage
Vr-g	dc	Vr-g	ac	ring-ground voltage
It(ma)	dc			tip (loop) current

- 6.4.1 V t-r dc or ac:** These selections place the meter across the Tip and Ring leads of the Loop input jack (the line). DC measurements result in the voltage displayed numerically and on the bar graph. AC measurements display the voltage numerically and graphically and give a frequency measurement.
- 6.4.2 V cm dc or ac:** These selections measures the voltage difference or delta between the Tip and Ring leads (V) of the LOOP input jack. The differential voltage measured is referenced to CO ground which is connected to the sleeve lead, or can be connected to a binding post on the rear of the unit.
- 6.4.3 V t-g dc or ac:** These selections place the meter across the Tip lead with reference to the Ground supplied on the sleeve of the LOOP input jack. The measurements are displayed in the same manner as V t-r measurements.
- 6.4.4 V r-g dc or ac:** These selections place the meter across the Ring lead with reference to the Ground supplied on the sleeve of the LOOP input jack. The measurements are displayed in the same manner as V t-r measurements.
- 6.4.5 It (mA) dc:** This selection places the meter in series with the Tip lead of the LOOP input jack. The measurement will be displayed numerically and graphically representing the Loop current being drawn by the Terminal/Line equipment.

The current measurement circuit has a 500mA slow blow fuse in series with the Tip sense circuit. Excessive current will open the fuse and disable the current measurements. See Section 1 for instructions on fuse replacement.

When performing current measurements, holding resistance of 10 Ω , 330 Ω , or 430 Ω can be selected. With the two higher-resistance settings, the measured current may drop after 10 minutes hold time due to heating of the line feed inductor.

6.4.6 Tone: This selection is used to measure Level and Frequency of Tones present on the Tip and Ring of the LOOP input jack. The Level is displayed in dBm and the frequency is displayed in Hz. A measured value of "UNDER" in the Level display indicates the measurement is lower than the acceptable limit. (dBm < -40). The measure display for the tone selection is as follows:

Tone	=	- 10	dBm	1004	Hz
Vt-r dc	=	- 38.9	■■■■■■■■

6.5 E & M and SF – ANALOG MEASURE

For E & M the measurements described in sub-sections 6.5.1 through 6.5.5 are made at the E & M jacks labeled TX/2W, RX, E/M and SB/SG on the front panel. For SF only the TX and RX jacks and measurements apply. Use as many 48–0047, 48–0048, or 48–0062 cables as are needed. The DC and AC MEASURE selections described are listed below in the order presented (beginning at top of left column) as the MENU up key is pressed:

				Description of Measurements
			TX Tone	transmit tip-ring tone (dBm and Hz)
			RX Tone	receive tip-ring tone (dBm and Hz)
TX Vt-r	dc	TX Vt-r	ac	transmit tip-ring voltage
TX Vcm	dc	TX Vcm	ac	transmit tip & ring common mode
RX Vt-r	dc	RX Vt-r	ac	receive tip-ring voltage
RX Vcm	dc	RX Vcm	ac	receive tip & ring common mode
Ve	dc	Ve	ac	E-lead tip-ground voltage
Vsg	dc	Vsg	ac	SG-lead ring-ground voltage
Vm	dc	Vm	ac	M-lead ring-ground voltage
Vsb	dc	Vsb	ac	SB-lead tip-ground voltage

- 6.5.1 TX Vt-r or RX Vt-r, dc or ac:** These selections connect the meter across the Tip and Ring leads of the E & M TX/2W or RX jack. DC measurements result in the voltage displayed numerically as well as on the bar graph. AC measurements display the voltage numerically and graphically, and also give a frequency measurement.
- 6.5.2 TX Vcm or RX Vcm, dc or ac:** These selections measure the voltage difference or delta between the Tip and Ring leads (ΔV) of the E & M TX/2W or RX input jack. The differential voltage measured is referenced to CO ground which must be connected to a binding post on the rear of the unit.
- 6.5.3 Ve or Vm, dc or ac:** These selections place the meter across the E or M lead with reference to the Ground supplied on the sleeve of the E/M input jack. DC measurements result in the voltage displayed numerically as well as on the bar graph. AC measurements display the voltage numerically and graphically and also give a frequency measurement.

- 6.5.4 Vsb or Vsg, dc or ac:** These selections place the meter across the SB or SG lead with reference to the Ground supplied on the sleeve of the SB/SG input jack. DC measurements result in the voltage displayed numerically as well as on the bar graph. AC measurements display the voltage numerically and graphically and also give a frequency measurement.
- 6.5.5 TX Tone or RX Tone:** These selections are used to measure Level and Frequency of Tones present on the Tip and Ring of the TX/2W or RX input jack. The Level is displayed in dBm and the frequency is displayed in Hz. A measured value of "UNDER" in the Level display indicates the measurement is lower than the acceptable limit (dBm < -40). The tone display is similar to the one shown under 6.4.6.

6.6 E & M and SF – ANALOG MEASURE

The measurements described in sub-sections 6.6.1 through 6.6.7 are made at the PCM1 jacks labeled TX/2W and RX, and the PCM2 jacks labeled TX or RX on the front panel. Use as many 48-0047, or 48-0048 cables as are needed. The MEASURE selections described are listed in the order presented (beginning at top of left column) as the MENU up key is pressed:

		Description of Measurements
TX1 Vcm dc	TX1 Vcm ac	PCM1 Transmit tip & ring common mode
RX1 dBdsx		PCM1 Received tip-ring bipolar amplitude
RX1 Vcm dc	RX1 Vcm ac	PCM1 Receive tip & ring common mode
TX2 Vcm dc	TX2 Vcm ac	PCM2 Transmit tip & ring common mode
RX2 dBdsx		PCM2 Received tip-ring bipolar amplitude
RX2 Vcm dc	RX2 Vcm ac	PCM2 Receive tip & ring common mode
TX1 Tone		PCM1 Transmit CHANnel tone (DBm and Hz)
RX1 Tone		PCM1 Receive CHANnel tone (DBm and Hz)
TX2 Tone		PCM2 Transmit CHANnel tone (DBm and Hz)
RX2 Tone		PCM2 Receive CHANnel tone (DBm and Hz)

- 6.6.1 TX1 Vcm or TX2 Vcm, dc or ac:** These selections measure the voltage difference or delta between the Tip and Ring leads (V) of the PCM1 TX or PCM2 TX input jack. The differential voltage measured is referenced to CO ground which can be connected to a binding post on the rear of the unit.
- 6.6.2 RX1 Vcm or RX2 Vcm, dc or ac:** These selections measure the voltage difference or delta between the Tip and Ring leads (V) of the PCM1 RX or PCM2 RX input jack. The differential voltage measured is referenced to earth ground rather than CO ground. The differential voltage measured is referenced to CO ground which can be connected to a binding post on the rear of the unit.
- 6.6.3 TX1 Tone or TX2 Tone:** These selections are used to measure Level and Frequency of Tones present on the selected channel of the PCM1 TX or PCM2 TX input jack. The Level is displayed in dBm and the frequency is displayed in Hz. A measured value of "UNDER" in the Level display indicates the measurement is lower than the acceptable limit. (dBm < -40).

- 6.6.4 RX1 Tone or RX2 Tone:** These selections are used to measure Level and Frequency of Tones present on the selected channel of the PCM1 RX or PCM2 RX input jack. The Level is displayed in dBm and the frequency is displayed in Hz. A measured value of "UNDER" in the Level display indicates the measurement is lower than the acceptable limit. (dBm < -40).
- 6.6.5 RX1 dBdsx or RX2 dBdsx:** These selections are used to measure the received bipolar amplitude of the PCM signals from the DSX bay at the PCM1 RX or PCM2 RX jack. The measured value is dependent on the Test Set MODE of the AM8a as described in 6.6.6 and 6.6.7.
- 6.6.6 RX1 dBdsx or RX2 dBdsx in Emulation Mode:** When in EMULATE, the PCM1 or PCM2 RX jack is connected to the RX jack at the DSX. The measurement will have zero gain compensation added to the measurement.
- 6.6.7 RX1 dBdsx or RX2 dBdsx in Monitor Mode:** When in MONITOR, the AM8a PCM1 or PCM2 RX jack is connected to the DSX Monitor jack. The measured value will have a gain compensation added to compensate for the signal attenuation of the 430 resistors in the DSX monitor jack.

NOTE: This applies also to measurements made while in a Drop & Insert Configuration (Rpt 1 to 2 or Rpt 2 to 1) since Drop & Insert also must have both RX jacks connected to the Monitor jacks of the DSX.

6.7 NOISE MEASURE

This MEASURE display is available for all Trunk types.



The display measures the Idle-Channel Noise between Tip and Ring of any selected LOOP, RX or TX jacks, except for PCM. On PCM, the measurement is made internally on any of the 24 selectable TX or RX channels.

There are two filters available for noise weighting of the noise measurement. The FLAT filter will have 0 dB of attenuation of the noise on the line up to 3500 Hz. The CMSG filter has weighting characteristics that are suitable for voice circuits.

6.8 PCM 1 and PCM 2 BIPOLAR VIOLATION (COUNT AND STATUS) MEASURE

There are two count (CNT) measure displays for the number of Bipolar Violations, Frame Errors, CRC errors, Slips, Yellow, and Blue alarms.

Two additional STATUS displays indicate if BLUE or YELLOW alarm conditions have occurred. These displays are for measurements taken at the PCM1 or PCM2 TX or RX jacks and are shown in the order of MENU up arrow selection:

PCM1 : BPV	FERR	CRC	SLIPS	YELLOW	BLUE
CNT 512	8	0	0	0	0

PCM1 :	BLUE	YELLOW
STATUS :	NO	NO
	<input type="checkbox"/> or <input type="checkbox"/>	<input type="checkbox"/> or <input type="checkbox"/>
	YES	YES

PCM2 : BPV	FERR	CRC	SLIPS	YELLOW	BLUE
CNT 64	8	0	0	0	0

PCM2 :	BLUE	YELLOW
STATUS :	NO	NO
	<input type="checkbox"/> or <input type="checkbox"/>	<input type="checkbox"/> or <input type="checkbox"/>
	YES	YES

Sub-sections 6.8.1 through 6.8.6 describe each measurement on the CNT displays, and sub-sections 6.8.7 and 6.8.8 describe the measurements on the STATUS displays.

6.8.1 BPV: counts in increments of 64. This results in a change for every 64 BPV occurrences. A BPV occurs when two consecutive "1" pulses have the same polarity.

- 6.8.2 FERR:** counts frame errors in increments of 4. The result is a change every fourth Frame error. A Frame error occurs when an incorrect bit occurs as the frame bit.
- 6.8.3 CRC:** is used only in an ESF framing mode. The resolution of the counter is 1. A CRC is counted when the calculated CRC on the receiver (AM8a) does not match the CRC sent as part of the next ESF.
- 6.8.4 SLIPS:** counts the number of times there is an insertion or deletion of data bits in the data stream. A slip is commonly due to buffer overflow or underflow of the network equipment.
- 6.8.5 YELLOW:** counts the number of yellow alarms received from the transmitting equipment indicating the loss of synchronization to its received signal. The AM8a will count a yellow alarm when this condition exists for more than 600ms. Once the yellow alarm condition is removed, the condition must be absent for a 200ms blanking interval. The conditions for YELLOW are:
- For D3/D4 framing, bit 2 set to a "zero" for all 24 time slots.
 - For ESF, the yellow alarm is generated by a 16 bit stream, 8 "1" bits followed by 8 "0" bits. The same timing conditions as D3/D4 are used.
- 6.8.6 BLUE:** counts the number of blue alarm conditions detected. The blue alarm is present when two (2) frames of "1" bits and an out-of-frame condition exists.
- 6.8.7 STATUS BLUE:** is YES when the receiver has detected two (2) frames of "1"s and an out-of-frame condition (refer to 6.8.6, above).
- 6.8.8 STATUS YELLOW:** is YES when the receiver has detected a "0" in the bit 2 positions of every DS1 channel (for further definition refer to 6.8.5).

6.9 PCM 1 OR PCM 2 FRAME SYNC MEASURE

This display allows the user to monitor the phase relationship between the spans connected to the PCM1 RX and TX jacks or the PCM2 RX and TX jacks. The indication should remain stable without any change or jitter occurring.

PCM TX FRAME SYNC:
PCM RX FRAME SYNC:

The user may align the indicators by pressing [SHIFT] then [CANCEL] for better comparison. This display is also used for Drop & Insert (Rpt 1 to 2 or Rpt 2 to 1) testing.

6.10 PCM 1 OR PCM 2 TX OR RX A/B MEASURE

This display provides a view of the signaling bits of all 24 time-slots for both the transmit and receive T1 and SLC[®]96 I (Mode I) Spans.

CAUTION: *This display is only valid when the AM8a is in MONITOR mode. Readings are meaningless in EMULATE mode.*

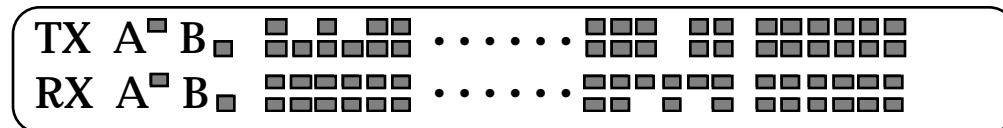

An A-bit or B-bit indication, shown by a shaded rectangle, means that the time-slot is active. Time-slot 01 is the bit to the far left and time-slot 24 is to the far right of the display.

Dots are displayed in all bit positions (shown for illustration only in slot 7-12 locations) if the AM8a is in an invalid mode for this display.

This display is useful for locating an idle voice channel before running Drop & Insert tests. Select a time-slot which displays inactive status in monitor mode before the selection of emulate mode to run the test (Rpt 1 to 2 or Rpt 2 to 1).

- 6.10.1 T1 Time-Slot to Voice Channel Assignment:** For T1 spans, the time-slot is equivalent to the channel number. This display is not used for SLC[®]96 Mode II.
- 6.10.2 SLC[®]96 Mode I Time-Slot to Voice Channel Assignment:** Refer to Figure 6-5 for the assignment of voice channels to time slots for SLC[®]96 Mode I.
- 6.10.3 SLC[®]96 Mode II Time-Slot to Voice Channel Assignment:** The TX or RX A/B Measure display is not useful for SLC[®]96 Mode II. Assignment of Time-Slots to Voice Channels is dynamic in SLC[®]96 Mode II. To determine which voice channel is active, refer to the Concentrator Field Message (a and b events) which can be monitored on the data link (CHAN=-97). For further details refer to Sections 1.2.2, 2.5.3, and 2.5.4.

NOTE: Active RX and TX test channels and time slots can also be determined by display of the Maintenance Message, described in sub-section 6.11.3.

Time Slot	SLC®96 Mode I Channel Number Assignment by Shelf			
	A	B	C	D
01	01	25	49	73
02	13	37	61	85
03	02	26	50	74
04	14	38	62	86
05	03	27	51	75
06	15	39	63	87
07	04	28	52	76
08	16	40	64	88
09	05	29	53	77
10	17	41	65	89
11	06	30	54	78
12	18	42	66	90
13	07	31	55	79
14	19	43	67	91
15	08	32	56	80
16	20	44	68	92
17	09	33	57	81
18	21	45	69	93
19	10	34	58	82
20	22	46	70	94
21	11	35	59	83
22	23	47	71	95
23	12	36	60	84
24	24	48	72	96

CHAN parameter in PCM CONFIG 1 menu selects either Time Slot or Channel Number (prefaced by - sign). 0-entry will cause monitoring of first time slot that becomes active (assigned channel goes off-hook).

Figure 6-5. SLC®96 Mode 1 Channel Number to Time Slot Assignments

6.11 SLC®96 MODE I OR II MESSAGES

When the AM8a is monitoring the RX or TX lines of a SLC®96 I or II (Mode I or Mode II) PCM link, three additional metering displays are available. These displays are the result of the decoding of bits in the PCM data stream.

NOTE: A SLC®96 RX line or TX line is also referred to as a "half-span" in some PCM descriptions.

6.11.1 ALARM TX or RX: provides an indication of alarm conditions detected on the link. For both TX and RX, there are two variations of the metering format. The one displayed is dependent on how the monitored switch is equipped.

The upper display shows 15 conditions which can be reported by the position of an "A". The lower display shows 10 conditions. (In an actual display both lines will usually have the same format.)

Figure 6-6 shows the display and identifies the Alarm Conditions. This is a dynamic display which will change as alarms occur. Alarm messages also will be printed via the RS 232 port.

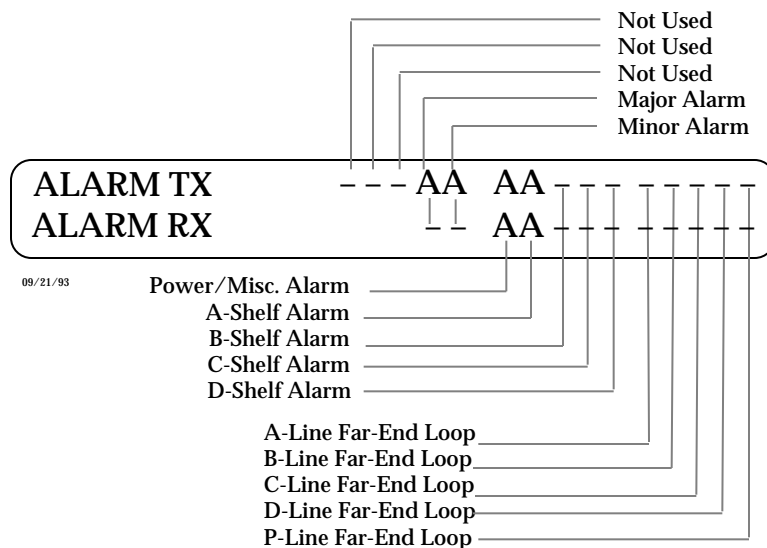
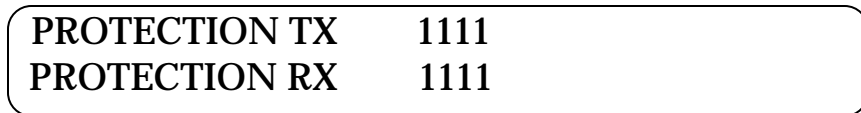

Figure 6-6. SLC®96 Alarm Conditions Meter Display

6.11.2 PROTECTION TX or RX: provides an indication of protection settings for the link.

Figure 6-7 shows the display and interprets the conditions represented by the "0" or "1" states of the display.



display	Message
1111	IDLE
1110	SWITCH LINE A RECEIVE
1101	SWITCH LINE B TRANSMIT
1100	SWITCH LINE C TRANSMIT
1010	SWITCH LINE D TRANSMIT
0101	SWITCH LINE B TRANSMIT & RECEIVE
0100	SWITCH LINE C TRANSMIT & RECEIVE
0010	SWITCH LINE D TRANSMIT & RECEIVE

Figure 6-7. SLC®96 Alarm Conditions Meter Display

6.11.3 MAINTENANCE TX or RX: provides a display of status of maintenance messages for the link. The interpretation of the RX and TX displays depends upon whether the unit is functioning as a te/line (RT) or as a switch (LDS).

Figure 6-8 shows the display, and interprets the conditions represented by "0" or "1" states for either direction. This display also shows the channels and time-slot assignments during the test operation.

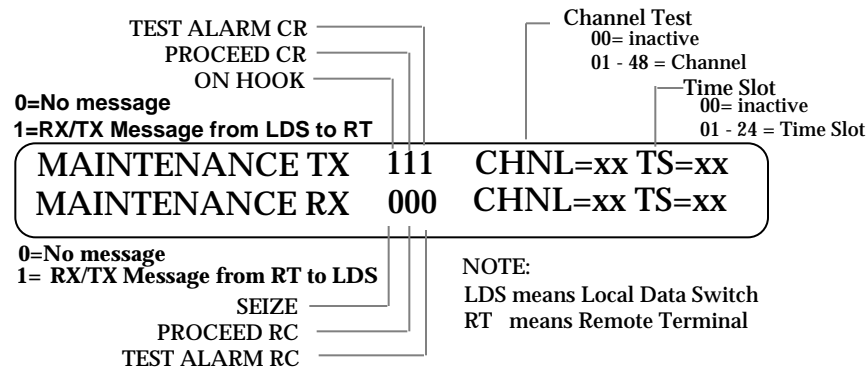

Figure 6-8. SLC®96 Alarm Conditions Meter Display

6.11.4 SLC®96 II Concentrator Field Messages: can be displayed as events when monitoring operations between a remote terminal (RT) and a local data switch (LDS). Events are generated as trunks are assigned or de-assigned, loop tests are run, and activities are reported and updated. The 4kBps data channel (CHAN=-97) must be selected. Refer to Sections 1.2.2, 2.5.3, and 2.5.4.

Meter Display

(18-0037)

AM8a Instruction Manual

7. RS232 ENTRIES AND PRINTOUTS

This section describes the RS232 commands that are equivalent to functions actuated by keys on the AM8a front panel. Also described are the printouts of SETUP menus, EVENTS/DETAILS, METER displays, LED displays, and AUTO PRINT reports. Finally, this section describes the RS232 connections for a terminal and for chained operation of more than one unit.

7.1 RS232 COMMAND DESCRIPTION

Functions activated by front panel keys (described in the previous sections) may also be executed by a terminal or computer connected to the RS232 port on the rear panel. The following rules apply to RS232 Commands:

- **An RS232 command is initiated by a "(" and executed when a ")" is received.** The ")" may also be used alone to repeat the last command sent. Only the characters between the "(" and the ")" are recognized as a command. (Other control characters, such as carriage return <CR> and line feed <LF> are not required and will be ignored.)
- **An "=" sign precedes a value change** in SETUP commands.
- **A help menu may be displayed by typing "?".** As directed in the menu, "1" through "6" can then be typed to get additional information.
- **The AM8a echoes all characters received after it has processed them.** The echo may be disabled if required, but leaving echo enabled is recommended while computer down-loading, for output control and error checking purposes.
- **A computer's down-load program** should be setup to wait for the echo of the previously sent character prior to sending the next character. This ensures the AM8a has had adequate time to process the command and prevent a buffer overflow. This also prevents loss of data which may cause down-load failure.
- **The first letter of many commands** corresponds to pressing a key on the front panel for that function (e.g. "C for CONFIG'N, "E" for EMULATE, "A" for ANALYZE). Other commands may abbreviate a key and its action e.g: "SZ+" for SEIZE ON).

- **Front panel key actions which are alternate-action toggles** are controlled by a "+" for ON or "-" for OFF. For PCM monitoring, the TIMS key has a three-position selection that uses a "#", (e.g: "TI+" for TIMS ON, "TI#" for TIMS reverse jack connections, and "TI-" for TIMS OFF).
- **Display menus will change as some commands are entered** (unless the display has been deactivated by an "(AY-)" command). A display can be printed with a (PDS) print-display command.
- **If units are chained, the command "!u" (where u=A through O corresponding to units 1 through 15) must precede commands to the unit** (refer to 7.3.3).

7.1.1 Terminal Commands: The RS232 terminal commands are shown in Figure 7-1. These commands do not correspond to keys on the unit. They control the interaction between the terminal (or computer) and the RS232 port. Refer to 7.3.2 for information on connecting terminal to unit.

7.1.2 Printer Commands: (PDS) and other commands for printing are listed in Figure 7-2. This figure also identifies equivalent front panel actions. The formats of the printouts are shown in the Figures described under 7.2.

7.1.3 SETUP Menu Commands for CONFIG, EMULATE, and ANALYZE: The RS232 SETUP Menu commands are listed Figures 7-3, 7-4, and 7-5, which also provide a quick reference to the Section 2, 3, and 4 sub-sections that provide detailed descriptions of menu displays and parameter entries. These commands are the equivalent to front panel key actions after the operator activates the [CONFIG'N], [ANALYZE], or [EMULATE] key functions.

- 7.1.3.1 Display Menu:** To display a menu, type a command that corresponds to any parameter within that menu. The menu will then be displayed on the AM8a. For example: (CTD) or (CEM) displays the MODE CONFIGURE menu.
- 7.1.3.2 Change Parameter:** To change a parameter, find the command that sets the parameter within a menu. Type the command then an equal "=" sign. After the equal sign there are two kinds of values that can be entered, followed by the closing ")".
- A Code Value: This is a code from 00 through 07 (leading "0" may be omitted). Each code corresponds to a parameter setting that is not numeric, for example (refer to Figure 7-3):
 (CTD=00) or (CTD=0) sets MODE CONFIG: IMITATE to te/line
 (CTC=02) or (CTC=2) sets PCM: FRAMING to SLC®96
 - A Numeric Value: This is an entry that directly sets a numeric value into the parameter, for example:
 (CSM=1200) sets the CIRCUIT: ANALOG IMPEDANCE to 1200 ohms
- 7.1.3.3 Print Menu:** If not already displayed, the menu with the changed parameter must be displayed by a (PDS) command. For example, if the DISPLAY CONFIG menu containing CONTRAST was not displayed when the (CCT=3) command was entered, type (CCT). To print the displayed menu, follow with (PDS), and the menu will be printed, showing the parameter value that has been entered:
- | | | | |
|----------|----------------|----------|-----------|
| DISPLAY: | MODE | CONTRAST | BACKLIGHT |
| CONFIG: | new call reset | 3 | on 5min |
- 7.1.4 AUTO DIAL Setup Commands:** The AUTO DIAL Setup key on the front panel permits the operator to enter up to 10 sequences of auto dialing (also referred to as "Speed Dial"). Details on AUTO DIAL are provided in Section 5. The RS232 equivalents for setting, storing, recalling, and dialing AUTO DIAL numbers are shown in Figure 7-6. Also shown are other commands related to dialing as well as the equivalent characters that are typed for the Data Entry keys for dialed digits (and other dialing sequence operations).

- 7.1.5 ON-OFF (Control Toggle) Commands:** The RS232 commands that simulate the toggle action of the keys on the lower-left of the front panel are shown in Figure 7-7. The "+", "-", and "#" characters following the command letters represent ON status, OFF status, and (for PCM monitor) reversed inputs. Refer to Section 1 for further description of the key functions.
- 7.1.6 CALL INITIATE (Signaling) Commands:** The RS232 commands that simulate the actions of the keys in the upper right side of the front panel are shown in Figure 7-8. The "+", and "-" keys are used to indicate the key states.
- 7.1.7 EVENTS DISPLAY Commands:** The RS232 commands that simulate the actions possible after the EVENTS DISPLAY function on the front panel has been activated, are shown in Figure 7-9. The commands permit the selection of a given event for detail printout, provide simulation of the ◀FIELD▶ keys on the front panel, and simulate the FREEZE and CANCEL keys.
- 7.1.8 METER DISPLAY Commands:** The RS232 commands that simulate the key actions after the METER DISPLAY function has been selected are shown in Figure 7-10. The MENU and MEASURE selections possible are dependent on the CIRCUIT CONFIGURE selections.

Table 7-1. RS232 Terminal Commands

COMMAND	DEFINITION
(Lxxx...x)	Log On with password xxx...x: A password is required if the setting of the CONFIG'N PASSWORD menu is YES. If NO, a password is not required, and the AM8a acts on RS232 commands as soon as a "?" or "(" character is received. Setting of the password is described at the end of this table. (The user may "white it out" of this manual, if desired.)
(B)	Log Off ("Bye"): This command should be entered as soon as the operator is finished with entering RS232 commands. In any case, there is an automatic Log off if there is no activity at the RS232 port for a period of two minutes. This is only required with passwords.
(EC+)	Echo On: This is the default status for the RS232 entries. When echo is on, every character received by the AM8a (on the RX line) results in the AM8a returning the command on its TX line. A terminal set in full-duplex mode will print the character, thereby acknowledging that the AM8a has received it. If commands are output from a computer, the computer program should be written to wait for the echoed character and check it.

COMMAND	DEFINITION
(EC-)	Echo Off: When echo is off, the AM8a will not echo received characters. A terminal will have to be set to half-duplex so the operator can monitor what is being entered. This mode could be used for a high-speed dump of commands by a computer, but is not recommended because error-checking cannot be implemented.
(AY+)	Enable front panel display and keypad: This is the default status for the AM8a. Any entry made at the keypad or via the RS232 port is displayed. When in operation as a line monitor or emulator, events are displayed.
(AYK)	Disable front panel keypad: This is a "safety" setting which prevents a local operator at an AM8a from using the keypad to change entries made via the RS232 port; however, the display remains active.
(AY-)	Disable front panel display and keypad: This command disables both the display and the keypad. No further events or entries from the RS232 port will be displayed. If this command is entered, the only way to control or monitor the AM8a is through the RS232 port.
(XYZxxx.x)	Set new password xxx...x: The password is 30 characters maximum and can not contain the characters ",", "!", or "?".

Table 7-2. RS232 Printing Commands

COMMAND	DEFINITION
(PDS)	Print Display Screen: This command prints both lines of any display which has been called up by a preceding command.
(PFL)	Print Front Panel LEDs: DISPLAY/SETUP mode, INPUT, TIMS, TALK, and AUTO indicators. Prints the status of the LEDs as ON or OFF. It is equivalent to looking at LEDs on the front panel.
(PET)	Print Events Top Line: This command prints the string of events that are displayed on the Top Line of the display. It is equivalent to pressing [SHIFT] then [PRINT] briefly (short print) while the EVENTS DISPLAY function is activated.
(PEB)	Print Event Both-lines: This command prints Events and Details. It is equivalent to pressing PRINT for two seconds (long print) while the EVENTS DISPLAY function is activated.
(PMO)	Print Meter Only: This command forces display of the first METER menu and prints all meter displays that apply to the METER settings.
(PCO)	Print Configuration Only: This command prints all configuration parameters. It is equivalent to pressing [SHIFT] then [PRINT] briefly (short print) while the SETUP CONFIG'N DISPLAY function is activated.
(PEO)	Print Emulate Only: This command prints all emulation parameters. It is equivalent to pressing [SHIFT] then [PRINT] briefly (short print) while the SETUP EMULATE function is activated.

(PAO)	Print Analyze Only: This command prints all analyze parameters. It is equivalent to pressing [SHIFT] then [PRINT] briefly (short print) while the SETUP AUTO DIAL function is activated.
(PSO)	Print Speed/Auto Dial Only: This command prints current auto-dial number. It is equivalent to pressing [SHIFT] then [PRINT] briefly (short print) while the SETUP ANALYZE function is activated.
(PAL)	Print All SETUP: This command prints all parameters that are appropriate to the configuration and operating mode. It is equivalent to pressing [SHIFT] then [PRINT] for two seconds (long print) while any of the SETUP functions are activated.
(POM=nn)	Print One Memory (where nn = 0-19 for Configure parameters, nn = 20-39 for Emulate and Analyze parameters, or nn = 40 for all Power Off Recall parameters. This command could be issued after doing a store command (Znn). This command is not the same as doing a recall (Rnn) followed by a (PAL), since operating parameters are not changed.

Table 7-3. RS232 CONFIGURATION Menu Commands

COMMAND	DEFINITION
(R0) – (R19)	RECALL CONFIG'N SETUPs from location ID 0 through ID 19. [SHIFT] + [RECALL] + [location ID] keys.
(R40)	RECALL all SETUPs from last power down. [SHIFT] + [RECALL] + [*] keys.
(Z0) – (Z19)	STORE CONFIG'N SETUPs from location ID 0 through ID 19. [SHIFT] + [STORE] + [location ID] keys.
(CTD)	MODE: IMITATE. (CTD = 00) for te/line. (CTD = 01) for <switch>. 2.1.1
(CEM)	MODE: MODE. (CEM = 00) for emulate. (CEM = 01) for <monitor>. 2.1.2
(CIR)	CIRCUIT: ANALOG IMPEDANCE. (CIR) = 135, 600, <900>, or 1200. 2.2.1
(CTA)	CIRCUIT: ANALOG/PCM. (CTA = 00) for analog, (CTA = 01) for pcm int clk, (CTA = 02) for <pcm loop clk>. 2.2.2
(CTC)	PCM: INPUT. (CTC = 00) for <pcm1 on>, (CTC = 01) for pcm2 on, (CTC = 02) for rpt1 to 2, (CTC = 03) for rpt2 to 1. 2.3.1 (1)
(CFM)	PCM: FRAMING. (CFM = 00) for <D3/D4>, (CFM = 01) for ESF, (CFM = 02) for SLC®96 I, (CFM = 03) for SLC®96 II. 2.3.2 (1)
(CZS)	PCM: ZEROSUP. (CZS = 00) for B8ZS, (CZS = 01) for ZCS, (CZS = 02) for <AMI>. 2.3.3 (1)
(CTH)	PCM: CHAN. (CTH = 00) for Channel <0> (random), (CTH = 24) to Channel 24, (CTH = -97) for SLC® Data link monitor, (CTH = -1) for SLC® Channel 1, (CTH = -96) to Channel 96. 2.3.4 (1)
(CS1)	PCM: OFF HK a/b. (CS1 = 00) for <auto>, (CS1 = 01) for 0/0, (CS1 = 02) for 0/1, (CS1 = 03) for 1/0, (CS1 = 04) for 1/1, (CS1 = 05) for 0/X, (CS1 = 06) for 1/X, (CS1 = 07) for X/0, (CS1 = 08) for X/1, (CS1 = 09) for. 2.3.5 (2)

(CS2)	PCM: ON HK a/b. See CS1 list. 2.3.5 (2)
(CTT)	TRUNK: TRUNK TYPE. (CTT = 00) for loop start, (CTT = 01) for ground start, (CTT = 02) for E&M 2W, (CTT = 03) for <E&M 4W>, (CTT = 04) for did, (CTT = 05) for sf. 2.4.1
(CST)	TRUNK: SLC® TYPE. (CST = 00) for <SINGLE PARTY>, (CST = 01) for UNIVERSAL V G. 2.4.2
(CET)	TRUNK: E&M TYPE. (CET = 00) for <I>, (CET = 01) for II, (CET = 02) for III, (CET = 03) for IV. 2.4.3
(CDM)	DISPLAY: MODE. (CDM = 00) for manual, (CDM = 01) for <new call reset>, (CDM = 02) for scroll. 2.5.1
(CDI)	DISPLAY: DIG DET. (CDI = 00) for wide, (CDI = 01) for <narrow>, (CDI = 02) for limit. 2.5.2
(CSM)	DISPLAY: SLC® MSG. (CSM = 0000000000) to (CSM = 1111111111) for 0000000000 to <0000000001> to 1111111111. 2.5.3
(CMK)	DISPLAY: "T/I" MASK. (CMK = 00) for <NO>, (CMK = 01) for YES. 2.5.5
(CBR)	RS232: BAUD RATE. (CBR) = 300, 1200, 2400, or <9600>. 2.6.1 (@)
(CPT)	RS232: PARITY. (CPT = 00) for <NO>, (CPT = 01) for ODD, (CPT = 02) for EVEN. 2.6.2 (@)
(CCD)	RS232: CR DELAY sec. (CCD = 0) for <0> to (CCD = 99) for 99 sec. 2.6.3 (@)
(CPW)	SECURITY: PASSWORD. (CPW = 00) for <no>, (CPW = 01) for yes. 2.7.1 (@)
(CSU)	SECURITY: SETUP PROTECT. (CSU = 00) for no, (CSU = 01) for <yes>. 2.7.2 (@)
(CAE)	PRINT: AUTO< PRINT. (CAE = 00) for <off>, (CAE = 01) for all calls, events only, (CAE = 02) for all calls, events & details, (CAE = 03) for flawed calls, events only, (CAE = 04) for flawed calls, events & details. 2.8.1 thru 2.8.5
(CMM)	CLOCK: DATE/MM. (CMM = 1) for 1 to (CMM = 12) for 12 (month). 2.9 (@)
(CDD)	CLOCK: DATE/DD. (CDD = 1) for 1 to (CDD = 31) for 31 (day of month). 2.9 (@)
(CYY)	CLOCK: DATE/YY. (CYY = 0) for 0 to (CYY = 99) for 99 (last 2-digits of year). 2.9 (@)
(CHH)	CLOCK: TIME/HH. (CHH = 0) for 0 to (CHH = 23) for 23 (hour). 2.9 (@)
(CMT)	CLOCK: TIME/HH. (CMT = 0) for 0 to (CMT = 59) for 59 (minutes). 2.9 (@)
No RS232 Command	AM8a: CPU DSP0 DSP1 105 100 100 Version is local display 2.10

The first two RS232 commands are equivalent to the RECALL and STORE key functions on the front panel for SETUP selected. The remaining commands are listed in the order of the equivalent AM8a front panel LCD menu displays as the MENU, FIELD, and VALUE keys are pressed.

The block to the right of the command shows menu text (sufficient for identification) and the selection-alternates (as displayed). Default values (factory-supplied) are shown within “<”;

not part of the menu display.

A command begins with an “(“ followed by a three-letter code and, optionally, an “=” sign, and either a two-digit code or a parameter value. A command ends with a “)”.

To display a menu, type only a command code for a parameter on the menu; e.g., (CTD) or (CEM) for the TEST SET: ... menu. To print the menu, type the print-display command, (PDS).

To change a parameter, type the command for the parameter, an “=” sign, and a code value (leading 0 may be omitted). E.g., (CTD=1) to set the MODE:IMITATE to “switch”; or a parameter value, e.g., (CTH=5) to set the PCM:CHAN to channel 5. Parameter change commands will not display the menu. If the menu is already displayed, the change will be seen.

To display a menu that has been changed, enter the display command; e.g., (CTH), type the print-display command (PDS).

Manual subsection numbers where the parameter is described in detail are shown in bold type following the parameter description; e.g., **2.1.1**. A **(1)**, **(2)**, or a **(3)** following the subsection number indicates that an additional menu must be displayed; e.g., PCM CONFIG 1 and PCM CONFIG 2. An **(@)** following the subsection number indicates that the parameter must be changed by the operator, not stored or recalled.

NOTE: MF(R1) digits will not be seen if DIALTONE is used as a Start Signal.

Table 7-4. RS232 EMULATE Menu Commands

COMMAND	DEFINITION
(R20) – (R39)	RECALL EMULATE/ANALYZE SETUPs from location ID 20 through ID 39. [SHIFT] + [RECALL] + [location ID] keys.
(R40)	RECALL all SETUPs from last power down. [SHIFT] + [RECALL] + [*] keys.
(Z20) – (Z39)	STORE EMULATE/ANALYZE SETUPs from location ID 20 through ID 39. [SHIFT] + [STORE] + [location ID] keys.
(ELV)	LOOP: VOLTAGEvdc. (ELV = 20) for 20 to <48> to (ELV = 72) for 72 volts. 3.1.1
(ELL)	LOOP: LENGTH ohm. (ELL) = 0, 300, 600, 900, <1200>, 1500, 1800, or 2100. 3.1.2
(EIC)	TERMINATION: 2.16uf. (EIC = 00) for <in>, (EIC = 01) for out. 3.2.1
(EDH)	TERMINATION: DC HOLD. (EDH) = 10ohm, <330ohm>, or 430ohm. 3.2.2
(ELT)	DIALING: LOOP TYPE. (ELT = 00) for <pulse>, (ELT = 01) for dtmf, (ELT = 02) for mf(R1). 3.3.1
(ESS)	DIALING: START SIGNAL. (ESS = 00) for immediate, (ESS = 01) for <wink>, (ESS = 02) for delay, (ESS = 03) for dial tone. 3.3.2
(EPS)	PULSE: SPEEDpps. (EPS) = 5 to <10> to 25. 3.4.1
(EPB)	PULSE: BREAK%. (EPB) = 40 to <60> to 85. 3.4.2
(EPI)	PULSE: INTRDIGITms. (EPI) = 120 to <600> to 999. 3.4.3
(ET1)	DTMF/MF: HI: dBm. (ET1) = -40 to <-7> to -3. 3.5.1 (1)
(ET2)	DTMF/MF: HI/hz%. (ET2) = -5.0 to <0.0> to +5. 3.5.1 (1)
(ET3)	DTMF/MF: LO: dBm. (ET3) = -40 to <-7> to -3. 3.5.2 (1)
(ET4)	DTMF/MF: LO/hz%. (ET4) = -5.0 to <0.0> to +5. 3.5.2 (1)
(EEN)	DTMF/MF: ON. (EEN) = -25 to <50> to 99. 3.6.1 (2)
(EEF)	DTMF/MF: OFFms. (EEF) = -25 to <50> to 99msec. 3.6.1 (2)
(EHL)	SEND TONE: LEVELdBm. (EHL) = -40 to <-10> to 0. 3.7.1
(EHF)	SEND TONE: FREQUENCYhz. (EHF) = 300 to <1004> to 3300. 3.7.2
(ED1)	DIAL TONE: ON. (ED1) = 0 to <9999>msec (Dial Tone 1 ON-Time). 3.8 (1)
(ED2)	DIAL TONE: OFFms. (ED2) = <0> to 9999 msec (Dial Tone 1 OFF-Time). 3.8 (1)
(ED3)	DIAL TONE: ...ON... . (ED3) = <0> to 9999 msec (Dial Tone 2 ON-Time). 3.8 (1)
(ED4)	DIAL TONE: ... /OFFms. (ED4) = <0> to 9999 msec (Dial Tone 2 OFF-Time). 3.8 (1)
(ED5)	DIAL TONE: ...ON. (ED5) = <0> to 9999 msec (Dial Tone 3 ON-Time). 3.8 (1)
(ED6)	DIAL TONE: /OFFms. (ED6) = <0> to 9999 msec (Dial Tone 3 OFF-Time). 3.8 (1)
(EDA)	DIAL TONE: T1:dBm. (EDA) = -40 to <-13> to -3 (Dial Tone 1 Level). 3.9.1 (2)

(EDB)	DIAL TONE: T1:/Hz. (EDB) = 0;300 to <350> to 3300 (Dial Tone 1 Frequency). 3.9.1 (2)
(EDC)	DIAL TONE: T2:dBm. (EDC) = -40 to <-13> to -3 (Dial Tone 2 Level). 3.9.2 (2)
(EDD)	DIAL TONE: /FREQ. (EDB) = 15 to <250> to 9999 Hz (seizure-to-dial tone delay). 3.9.2 (2)
(EDT)	DIAL TONE: DL SNDms. (EDT) = 0;300 to <440> to 3300 Hz (Dial Tone 2 Frequency). 3.9.3 (2)
(EFS)	RECALL: HOOKFLASHms. (EFS) = 15 to <500> to 999. 3.10.1
(EUB)	RECALL: LINE UNBALms. (EUB) = 15 to <500> to 9999 msec. 3.10.2
(ER1)	RINGING: ON. (ER1) = 0 to <2000> to 5000msec (Ring 1 ON-Time) 3.11.1 (1)
(ER2)	RINGING: /OFFms (ER2) = 0 to <4000> to 9999msec (Ring 1 OFF-Time) 3.11.1 (1)
(ER3)	RINGING: ...ON... (ER3) = <0> to 5000msec (Ring 2 ON-Time) 3.11.2 (1)
(ER4)	RINGING: .../OFFms (ER4) = <0> to 9999msec (Ring 2 OFF-Time) 3.11.2 (1)
(ER5)	RINGING: ...ON. (ER5) = <0> to 5000msec (Ring 3 ON-Time) 3.11.2 (1)
(ER6)	RINGING: .../OFFms (ER6) = <0> to 9999msec (Ring 3 OFF-Time) 3.11.2 (1)
(ERV)	RINGING: VOLTAGEvrms. (ERV) = 30 to <85> to 105 3.12.1 (2)
(ERF)	RINGING: FREQUENCYhz. (ERF) = 15.0 to <20.0> to 70.0 3.12.2 (2)
(ELB)	START TIME: DLY BGN. (ELB) = 15 to <50> to 999 3.13.1
(ELE)	START TIME: DLY/ENDms. (ELE) = 100 to <250> to 9999msec 3.13.1
(EWB)	START TIME: WINK: BGN. (EWB) = 15 to <50> to 999 3.13.2
(EWD)	START TIME: WINK:/DURms. (EWD) = 50 to <250> to 999msec 3.13.2
(ESL)	SF: LEVELdBm. (ESL) = -40 to <-10> to 0 dBm. 3.14.1
(ESF)	SF: FREQ+%hz. (ESF) = -2.0 to <0.0> to 2.0% 3.14.2

Table 7-5. RS232 ANALYZE Menu Commands

COMMAND	DEFINITION
(R20) – (R39)	RECALL EMULATE/ANALYZE SETUPs from location ID 20 through ID 39. [SHIFT] + [RECALL] + [location ID] keys.
(R40)	RECALL all SETUPs from last power down. [SHIFT] + [RECALL] + [*] keys.
(Z20) – (Z39)	STORE EMULATE/ANALYZE SETUPs from location ID 20 through ID 39. [SHIFT] + [STORE] + [location ID] keys.
(AHF)	HOOK: FLASHms(min) (AHF) = 50 to <450> (Min.) to 1250 4.1.1
(AHD)	HOOK: DISCONNECTms(min) (AHD) = 50 to <1000> (Min.) to 1250 4.1.2
(AWD)	STRT SIG: EXPECTED TYPE. (AWD = 00) for <dialtone/wink>, (AWD = 01) for dialtone/delay. 4.2.1, 4.2.2

(ADA)	DT START: DIALTONE RCVDms (min). (ADA) = <0> to 9999. 4.3
(ADB)	DT START: DIALTONE RCVD /max. (ADB) = 0 to <3000> to 9999. 4.3
(AD1)	DLY STRT: STRT BGNms (min). (AD1) = 0 to <15> to 999. 4.4.1
(AD2)	DLY STRT: STRT BGN /max. (AD2) = 0 to <300> to 999. 4.4.1
(AD3)	DLY STRT: ENDms (min). (AD3) = 0 to <140> to 9999. 4.4.2
(AW1)	WINK STRT: WINK BGNms (min). (AW1) = <15> to 999. 4.5.1
(AW2)	WINK: DURms (min). (AW2) = 50 to <140> to 999. 4.5.1
(AW3)	WINK: DUR /max. (AW3) = 50 to <290> to 999. 4.5.2
(AP1)	PULSE: SPEEDpps (min). (AP1) = 5.0 to <8.0> (Min.) to 25.0. 4.6.1 (1)
(AP2)	PULSE: SPEED /max. (AP2) = 5.0 to <12.0> to 25.0. 4.6.1 (1)
(AP3)	PULSE: BREAK% (min). (AP3) = 20 to <50> to 85. 4.6.2 (1)
(AP4)	PULSE: DIAL BREAK /max. (AP4) = 20 to <70> to 85. 4.6.2 (1)
(AP5)	PULSE: INTRDIGIT (min). (AP5) = 120 to <300> to 999 msec. 4.7.1 (2)
(AT1)	DTMF/MF: LO BANDdb (min). (AT1) = -30 to <-15> to -3 dBm. 4.8.1 (1)
(AT2)	DTMF/MF: LO BAND /max. (AT2) = -30 to <-3> dBm. 4.8.2 (1)
(AT3)	DTMF/MF: HI BANDdb (min). (AT3) = -30 to <-15> to -3 dBm. 4.8.2 (1)
(AT4)	DTMF/MF: HI BAND /max. (AT4) = -30 to <-3> dBm. 4.8.2 (1)
(AT5)	DTMF/MF: TWISTdb (min). (AT5) = -12 to <-6> to +12. 4.9.2 (2)
(AT6)	DTMF/MF: TWIST /max. (AT6) = -12 to <6> to +12 dBm. 4.9.2 (2)
(AT7)	DTMF/MF: FREQ% (max). (AT7) = 0 to <1.5> (\pm) to 3.5 dBm. 4.9.1 (2)
(AT8)	DTMF/MF: TONE ON (min). (AT8) = 25 to <35> to 99 msec. 4.10.1 (3)
(AT9)	DTMF/MF: TONE/OFFms (min). (AT9) = 25 to <35> to 99 msec. 4.10.1 (3)
(ATA)	DTMF/MF: GUARDms. (ATA) = 0 to <20> to 99. 4.10.2 (3)
(ATT)	THRESHOLD: TONEdBm (min). (ATT) = -40 to <-30> to 0 dBm. 4.11.1
(AHT)	THRESHOLD: OFF HKvdc (min). (AHT) = 2 to <35> to 60 volts. 4.11.2

Table 7-6. RS232 Auto Dial Setup Commands

COMMAND	DEFINITION
(S0=ddd...d) thru (S9=ddd...d)	STORE AUTO DIAL number 0 up to 60 characters ddd...d. through STORE AUTO DIAL number 9 up to 60 characters ddd...d.
ddd...d	
1 thru 9, 0	Dialed digit 1 (TT, DP, or MF) through Dialed digit 9 (TT, DP, or MF) Dialed digit 0 (TT, DP, or MF)
*	* (TT) or KP (MF)
#	# (TT) or ST (MF)
A	A (TT or MF)
B	B (TT or MF)
C	C (TT or MF)
D	D (TT)
P	WAIT DT (Wait for Dial-Tone) [1]
W	WAIT WINK [2]
-	WAIT [3]
F	FLASH [4]
U	UNBALance (line) [5]
T	TOGGLE DIAL [6]
SPACE	BLANK [7]
(S0) thru (S9), (S*)	RECALL AUTO DIAL number 0 through RECALL AUTO DIAL number 9 RECALL last number dialed
[SHIFT] + [RECALL] + [0] through [9] or [*] (must be in EVENTS Display mode)	
(SD0) thru (SD9)	Speed Dial AUTO DIAL number 0 through Speed Dial AUTO DIAL number 9

Table 7-7. RS232 On-Off (Control Toggle) Commands

COMMAND	DEFINITION
(IP+)	INPUT (on)
(IP-)	INPUT (off)
(TI+)	TIMS (on): T/R -> TX/2W TX/2W -> TX/2W TIMS (on): R/X -> RX PCM -> TIMS <i>Selected Chan</i> RX RX TX TX
TI#)	TIMS (rev) PCM -> TIMS <i>Selected Chan</i> RX RX <i>monitor only</i> TX TX
(TI-)	TIMS (off)
(TK+)	TALK (Speakerphone on)
(TK-)	TALK (Speakerphone off)
(AU+)	AUTO (Auto call/answer on)
(AU-)	AUTO (Auto call/answer off)

Table 7-8. RS232 Call Initiate (Signaling) Commands

COMMAND	DEFINITION
(SZ+)	SEIZE (line on)
(SZ-)	SEIZE (line off)
(RI+)	RING (supply ring)
(RI-)	RING (remove ring)
(TN+)	SEND TONE (TONE on)
(TN-)	SEND TONE (TONE off)
(ST+)	START (Initiate signal)
(ST-)	START (Remove signal)
(RV+)	REV (Reverse polarity)
(RV-)	REV (Normal polarity)

Table 7-9. RS232 Events Display Commands

COMMAND	DEFINITION
(Vn)	EVENTS display including detailed event n (n = 0 to 79).
(VR)	EVENTS display and move cursor right.
(VL)	EVENTS display and move cursor left.
(VF)	FREEZE events.
(CN)	CANCEL (EVENT FREEZE or abort selection).

Table 7-10. RS232 Meter Display Commands (Analog Voltage Measurements)

COMMAND	DEFINITION															
(MV0) (MV1) (MV2) (MV3)	Display MEASURE/SCALE for Meter 1 and Meter 2. Typical: <table style="width:100%; border:none;"> <tr> <td style="width:33%;"></td> <td style="width:17%; text-align:center;">MEASURE</td> <td style="width:17%; text-align:center;">SCALE</td> <td style="width:17%; text-align:center;">MEASURE</td> <td style="width:17%; text-align:center;">SCALE</td> </tr> <tr> <td></td> <td style="text-align:center;">Vt-r dc</td> <td style="text-align:center;">100</td> <td style="text-align:center;">Vr-g dc</td> <td style="text-align:center;">5</td> </tr> <tr> <td></td> <td style="text-align:center;">Meter 1</td> <td></td> <td style="text-align:center;">Meter 2</td> <td></td> </tr> </table>		MEASURE	SCALE	MEASURE	SCALE		Vt-r dc	100	Vr-g dc	5		Meter 1		Meter 2	
	MEASURE	SCALE	MEASURE	SCALE												
	Vt-r dc	100	Vr-g dc	5												
	Meter 1		Meter 2													
(MV0=x)	Meter 1 MEASURE select. See Table 7-11 for the value of x.															
(MV1=n)	Meter 1 SCALE entry for MVV bar graph. n = .1 through 300.															
(MV2=x)	Meter 2 MEASURE select. See Table 7-11 for the value of x.															
(MV3=n)	Meter 2 SCALE entry for MVV bar graph. n = .1 through 300.															
(MVV)	Meter 1 and Meter 2 analog and bar graph display. Typical: <table style="width:100%; border:none;"> <tr> <td style="width:33%;">t-r dc = 42.6</td> <td style="width:33%;">.</td> <td style="width:33%; text-align:right;">Meter 1</td> </tr> <tr> <td>r-g dc = 0.2</td> <td>.</td> <td style="text-align:right;">Meter 2</td> </tr> </table>	t-r dc = 42.6	Meter 1	r-g dc = 0.2	Meter 2									
t-r dc = 42.6	Meter 1														
r-g dc = 0.2	Meter 2														

Table 7-11. RS232 Meter Display Commands (Meter Selections)

(MV0=x) (MV2=x) x value	LOOP START GROUND START D.I.D	E&M 2W E&M 4W	SF	PCM 1 PCM 2
= 00	Vt-r dc	→	→	TX1 Vcm dc
= 01	Vcm dc	TX Vt-r dc	TX Vt-r dc	RX1 dBsx
= 02	Vt-g dc	TX Vcm dc	TX Vcm dc	RX1 Vcm dc
= 03	Vr-g dc	RX Vt-r dc	RX Vt-r dc	TX2 Vcm dc
= 04	It(ma) dc	RX Vcm dc	RX Vcm dc	RX2 dBsx
= 05	Tone	Ve dc	→	RX2 Vcm dc
= 06	Vt-r ac	Vsg dc	→	TX1 Tone
= 07	Vcm ac	Vsb dc	→	RX1 Tone
= 08	Vt-g ac	Vm	→	TX1 Tone
= 09	Vr-g ac	TX Tone	TX Tone	RX1 Tone

= 10	→	RX Tone	RX Tone	TX1 Vcm ac
= 11	→	TX Vt-r ac	TX Vt-r ac	RX1 Vcm ac
= 12	→	TX Vcm ac	TX Vcm ac	TX2 Vcm ac
= 13	→	RX Vt-r ac	RX Vt-r ac	RX2 Vcm ac
= 14	→	RX Vcm ac	RX Vcm ac	
= 15	→	Ve ac		
= 16	→	Vsg ac		
= 17	→	Vm ac		
= 18	→	Vsb ac		

Table 7-12. RS232 Meter Display Commands (PCM Measurements)

COMMAND	DEFINITION
(MP1)	Select PCM1 and display Bipolar Violation measurements. Typical: PCM1: BPV FERR CRC SLIPS YELLOW BLUE CNT 0 0 0 0 0 0
(MP3)	Select PCM1 and display Alarm Status. Typical: PCM1: BLUE YELLOW STATUS: NO YES
(MP2)	Select PCM2 and display Bipolar Violation measurements. Typical: PCM2: BPV FERR CRC SLIPS YELLOW BLUE CNT 0 0 0 0 0 0
(MP4)	Select PCM1 and display Alarm Status. Typical: PCM2: BLUE YELLOW STATUS: YES NO
(MPH)	Display Frame Sync Measurement for PCM1 or PCM2. Typical: PCM TX FRAME SYNC: PCM RX FRAME SYNC:
(MAB)	Display PCM TX and RX a/b Bits (Monitor Mode only) TX A-B_ . . . _ = . = . . . _ . . = . _ = RX A-B_ . . = = = Bit Indicators: - a on, b off _ b on, a off . both off = both on
(MAM)	Display SLC®96 Alarm Message Status. Typical: ALARM TX: ---AA A---- ALARM RX: -- AA----
(MPT)	Display SLC®96 Protection Message Status. Typical: PROTECTION TX: 1111 PROTECTION RX: 1110
(MMT)	Display SLC®96 Maintenance Message Status. Typical: MAINTENANCE TX: 000 CHNL= 00 TS= 00 MAINTENANCE RX: 111 CHNL= 00 TS= 00

Table 7-13. RS232 Meter Display Commands (Noise Measurements)

COMMAND	DEFINITION
(MNO) or (MN1)	Select Noise measurement display NOISE -65 dBrn INPUT TX FILTER CMSG
(MNO)	(MNO = 00) for Select Noise measurement INPUT TX. (MNO = 01) for Select Noise measurement INPUT RX.
(MN1)	(MN1 = 00) for Select Noise measurement FILTER CMSG. (MN1 = 01) for Select Noise measurement FILTER FLAT.

7.2 PRINTOUTS

A variety of printouts are available from the AM8a. The printouts may be manual or automatic. The MANUAL printouts are controlled by the PRINT key on the front panel or the RS232 Printing Commands shown in Table 7-2.

The automatic printing selections are provided in the PRINT CONFIG menu AUTOPRINT parameter. (Refer to 2.7 for description of this menu). The following sub-sections provide information on the print formats.

NOTE: Automatic printouts begin at the end of the start of the next call sequence.

- 7.2.1 **off:** No automatic printout will occur. Operator may use the [SHIFT] and [PRINT] keys for short or long print, or can use equivalent RS232 commands (PET) or (PEB) when printouts are required.
- 7.2.2 **all calls,events only:** The EVENT only printout will show the first line of the Events Display. This printout can have the same maximum length as the Events Display (80 characters). Figure 7-1 is a sample of an EVENT only printout. (This is also the printout that would result from a manual short printout while in EVENTS DISPLAY mode.)

>HX1x2765432654325h

Figure 7-1. Event-only Printout

NOTE: Any underlined characters indicate the Event originated from the switch. Refer to Section 1 for the explanation of the event codes.

7.2.3 all calls,events & details: The EVENTS & DETAILS printout will provide the Event from the first line of the Events Display, then the second line Analysis. This is repeated for each event. Figure 7-2 is a sample of an EVENTS & DETAILS Monitor mode printout (not based on EVENT printout described in the preceding sub-section). Figure 7-3 is a sample for ring details. (These printouts are also typical of Manual long print from the unit while in EVENTS DISPLAY mode.)

7.2.4 flawed calls,events only: Printout format is the same as shown in Figure 7-1. However, only those calls outside tolerance specified in the ANALYZE setup menus will be output, and an "*" at the end of the line will indicate the flawed call. Events which cannot be recognized will be indicated with a "?".

7.2.5 flawed calls, events & details: Printout format is the same as shown in Figures 7-2 or 7-3. An "*" will be shown following those events which are outside of tolerance.

```

> 02: 23: 18 12-28-92 Monitor Term/Line
H 00:00:00 Off Hook
X 00:00.194 Dial Tone Begin
1 00:01.483 T1 -06/697 -06/1209 1483/0051
x 00:01.586 DT End -10/439 -10/350
2 00:01.584 T2 -06/698 -07/1336 0050/0051
3 00:01.685 T3 -07/697 -06/1477 0050/0050
4 00:01.785 T4 -06/770 -06/1209 0049/0051
5 00:01.885 T5 -06/770 -06/1336 0050/0050
6 00:01.985 T6 -07/770 -06/1477 0051/0049
7 00:02.085 T7 -06/853 -06/1209 0050/0051
8 00:02.186 T8 -07/852 -06/1336 0050/0050
9 00:02.286 T9 -06/851 -07/1477 0049/0052
0 00:02.387 T0 -07/942 -06/1336 0050/0050
P 00:03.560 Supervision Begin
T 00:05.570 Tone Begin
t 00:05.798 Tone End -10 dBm 0697 hz
h 00:05.720 On Hook
p 00:06.245 Supervision End

```

Event Details

Elapsed Time Relative to Off Hook

Events generated from the switch

Events generated from the Term/Line

Figure 7-2. Events & Details Printout (Monitor Mode)

```

(PEB)                               RS232 Command Equivalent
EVENTS & DETAILS
> 16:32:15 08-16-91 Emulate
R 00:00:00   Ri ng Begi n 100.0v 20.0 hz`
r 00:01.924   Ri ng End
R 00:06:003   Ri ng Begi n 080.00v 20.0 hz
r 00:07.928   Ri ng End
R 00:12:006   Ri ng Begi n 081.00 20.0 hz
r 00:13.932   Ri ng End

```

Figure 7-3. Events & Details Printout (Emulate Mode)

7.2.6 Manual Short Print: To request a Short Print, press [SHIFT] then [PRINT] and data appropriate to what has been selected for display is printed. Figure 7-1 shows a short print in EVENTS DISPLAY, Figure 7-4 shows a METER DISPLAY (when first display has been selected), Figure 7-5 shows a SETUP DISPLAY for EMULATE parameters.

NOTE: The RS232 commands in "(" and the three columns to the right side are not in the printout. They are cross-reference aids. Only the lines appropriate to the configuration (indicated by *) are printed.

```

MEASURE   SCALE   MEASURE   SCALE
Vt-r dc   100   Vr-g dc   150

```

Figure 7-4. Manual Short Print (Meter Display Example)

(PE0)	RS232 command	equivalent	switch	te	PCM
Emulate setup					
Loop Voltage	†(ELV) =	48	*	-	-
Loop Length	(ELL) =	1200	*	*	-
Loop DC hold	(EDH) =	330	-	*	-
2.16 µF	(EIC) =	IN	*	*	-
Dialing type	(ELT) =	dial pulse	-	*	-
Dialing start signal	(ESS) =	wink	*	-	-
Unbalance Time	(EUB) =	500	-	-	-
Ringing Voltage	(ERV) =	085	*	-	-
Ringing Frequency	(ERF) =	20.0	*	-	-
Ring on time	(ER1) =	2000	*	-	-
Ring off time	(ER2) =	4000	*	-	-
Ring on time	(ER3) =	0000	*	-	-
Ring off time	(ER4) =	0000	*	-	-
Ring on time	(ER5) =	0000	*	-	-
Ring off time	(ER6) =	0000	*	-	-
Dial tone delay	(EDT) =	0250	*	-	*
Delay Begin	(ELB) =	0100	*	-	*
Delay End	(ELE) =	0250	*	-	*
Wink Begin	(EWB) =	100	*	-	*
Wink Duration	(EWD) =	250	*	-	*
Dial Tone Level (low)	(EDA) =	- 13	*	-	*
Dial Tone Frequency	(EDB) =	350	*	-	*
Dial Tone Level (high)	(EDC) =	- 13	*	-	*
Dial Tone Frequency	(EDD) =	440	*	-	*
Dial Tone on time	(ED1) =	9999	*	-	*
Dial Tone off time	(ED2) =	0000	*	-	*
Dial tone on time	(ED3) =	0000	*	-	*
Dial Tone off time	(ED4) =	0000	*	-	*
Dial tone on time	(ED5) =	0000	*	-	*
Dial Tone off time	(ED6) =	0000	*	-	*
Flash Time	(EFS) =	500	-	*	-
Pulse Dial Speed	(EPS) =	10	-	*	*
Pulse Dial % Break	(EPB) =	60	-	*	*
Pulse Dial IDT	(EPI) =	600	-	*	*
SF LEVEL	(ESL) =	- 10	-	-	-
SF FREQ%	(ESF) =	00.0	-	-	-
Tone Dial Level (low)	(ET3) =	- 07	-	*	*
Tone Dial Frequency Tol	(ET4) =	00.0	-	*	*
Tone Dial Level (high)	(ET1) =	- 07	-	*	*
Tone Dial Frequency Tol	(ET2) =	00.0	-	*	*
Tone Dial on time	(EEN) =	50	-	*	*
Tone Dial off time	(EEF) =	50	-	*	*
Hold Tone Level	(EHL) =	- 10	*	*	*
Hold Tone Frequency	(EHF) =	1004	*	*	*

† RS232 Command codes in "()" for reference; not printed (see Figure 7-4).

* Loop start parameters shown for analog switch and te.
Default parameters shown for PCM switch and te

Figure 7-5. Manual Short Print (EMULATE Analog Switch, Te, PCM Examples)

7.2.7 Manual Long Print: To obtain a Long Print, press [SHIFT] then [PRINT], then hold the [PRINT] key for 2 seconds. This will result in a Long Print, which prints all of the information available for EVENTS details, METER displays, or SETUP parameters.

Figure 7-6 shows a sample of a Long Print while in the METER Display.

```

(PMD)          RS232 command equivalent
Meter Display:

      MEASURE      SCALE      MEASURE      SCALE
      Vt-r dc     = 100      Vr-g dc     = 150
Vt-r dc = 47.6 ..... """" .....
Vr-g dc = -47.2 ..... """" .....

PCM1: BPV      FERR      CRC      SLIPS      YELLOW BLUE
CNT           0          0          0          0          0

PCM1:          BLUE      YELLOW
STATUS:        NO        NO

PCM2: BPV      FERR      CRC      SLIPS      YELLOW BLUE
CNT           0          0          0          0          0

PCM2:          BLUE      YELLOW
STATUS:        NO        NO

PCM TX FRAME SYNC: .....!..... (use CANCEL or "(CN)" command to align !)
PCM RX FRAME SYNC: .....!.....

NOISE ----- dBrn .....
INPUT      TX          FILTER      MSG

TX A-B_    ..._=. =..._ =..._ =..._ =..._
RX A-B_    ...=_ =..._ =..._ =..._ =..._

ALARM TX    -A--A AAA-A -A---
ALARM RX    -A AA--A --AA-

PROTECTION TX 0100
PROTECTION RX 0000

MAINTENANCE TX 000 CHAN= 13 TS= 02
MAINTENANCE RX 010 CHAN= 37 TS= 02
    
```

bit indicators
- : a on, b off
= : both on
_ : b on, a off
. : both off

Figure 7-6. Manual Long Print (Meter Display Example)

Figure 7-7 shows a sample of a Long Print for SETUP. This printout is for a unit in Monitor mode which is why "No emulation setup for Monitor type" appears in the printout.

When in the Emulate mode, "Analyze setup", and "Speed/auto dial setup" lists will contain the same parameters for all configurations. The "Configuration setup" and "Emulate setup" lists will contain the parameters that are appropriate to MODE: IMITATE (te/line or switch), CIRCUIT:ANALOG/PCM, or TRUNK: TRUNK TYPE parameter settings.

```

(PAL)
Configuration setup:
Test Set ID                † (CTD) = Switch
Test mode                  (CEM) = Monitor
Analog Impedance          (CIR) = 900
Trunk type                 (CTT) = E&M 4 Wire
* E&M type                 (CET) = 1
** Analog/PCM              (CTA) = PCM LOOP CLOCK
** PCM configuration        (CTC) = PCM1
** PCM framing              (CFM) = D3/D4
** PCM zero suppression    (CZS) = AMI
** PCM channel             (CTH) = 01
** OFF HK a/b              (CS1) = Auto
** ON HK a/b               (CS2) = Auto
** SLC® TYPE               (CST) = SINGLE PARTY
Display Mode              (CDM) = new call reset
DIGT DET                  (CDI) = narrow
SLC® MSG                  (CSM) = 0000000001
"T/t" MASK                (CMK) = No
@ RS232 Baudrate           (CBR) = 9600
@ RS232 Parity Setup       (CPT) = none parity
@ Carriage Return Delay   (CCD) = 00
@ Security Password        (CPW) = no
@ Security Setup Protect   (CSU) = yes
Auto Print Setup          (CAE) = off
@ DATE                    (CMM) (CDD) (CYY) = 05/19/93
@ TIME                    (CHH) (CMT) = 16:31:35
CPU Version                - = 105
DSP 0 Version              - = 100
DSP 1 Version              - = 100
No emulation setup for Monitor type

Analyze setup:
Hook flash time           †† (AHF) = 0450
Hook disconnect time      (AHD) = 1000
Start Signal Expected     (AWD) = Dial tone/Wink
Dial tone receive (min)   (ADA) = 0000
Dial tone receive (max)   (ADB) = 3000
Delay begin (min)         (AD1) = 0000
Delay begin (max)         (AD2) = 0300
Delay end (min)           (AD3) = 0140
Wink begin (min)          (AW1) = 0015
Wink duration (min)       (AW2) = 0140
Wink duration (max)       (AW3) = 0290
Dial pulse speed (min)    (AP1) = 080
Dial pulse speed (max)    (AP2) = 120
Dial pulse break (min)    (AP3) = 50
Dial pulse break (max)    (AP4) = 70
Dial pulse IDT (min)      (AP5) = 300
TD low band (min)         (AT1) = - 15
TD low band (max)         (AT2) = - 03
TD high band (min)        (AT3) = - 15
TD high band (max)        (AT4) = - 03
TD twist (min)           (AT5) = - 06
TD twist (max)           (AT6) = 06
TD frequency tolerance(max) (AT7) = 01.5
TD tone on time (min)     (AT8) = 35
TD tone off time (min)    (AT9) = 35
TD guard time            (ATA) = 20
Tone threshold (min)      (ATT) = - 30
ON/OFF Hook threshold (min) (AHT) = 35

Speed/auto dial setup:
number 0 = 1234567890
number 1 =
number 2 = 1213456789
number 4 = 1213T*456#T1213456
number 5 =
number 6 =
number 7 =
number 8 =
number 9 =

```

Figure 7-7. Manual Long Print (Setup Example)

<p>NOTES: † RS232 Command codes in "()" for reference; not printed (Table 7-3).</p> <p>* For E&M trunks in analog mode only.</p> <p>** For PCM inputs only</p> <p>@ Initial factory setting, once set, can only be changed by another operator entry .</p> <p>†† RS232 Command codes in "()" for reference; not printed (Table 7-5).</p>
--

7.3 RS232 REAR-PANEL CONNECTIONS

All RS232 connections are made at the rear panel of the unit. Figure 7-8 shows the rear panel of the unit. A single terminal is connected to the connector labeled "RS232". If units are chained, the AUX connector is also used. The POWER and LINE/TIMS connections are described in Sections 1 and 2.

7.3.1 Printer Cable (48-0084) Connection: A terminal or computer can be connected to the AM8a by means of a printer cable (P/N 48-0084) illustrated in Figure 7-9. This cable is specifically designed for use with an optional printer/terminal (P/N 24-0016) which is a 300 baud thermal printer. The cable may be used, however, with any external device which has the proper connector.

Another cable (not illustrated) which may be used is the Universal Printer Cable (P/N 48-0012). This cable brings out pin 2 (Transmit to terminal) to a Red wire, pin 3 (Receive from terminal) to a Green wire, and signal-ground to a Black wire.

The 25-pin female connector on the cable is plugged into the RS232 connector on the rear panel of the unit.

If units are chained, the printer cable is connected to the first ("A") unit in the chain.

The baud rate, parity, and CR delay for the RS232 port must be set to match the terminal's characteristics through the CONFIG'N SETUP menu.

<p>CAUTION: <i>Do not exceed 2400 baud rate when units are chained.</i></p>
--

7.3.2 Chaining Cable (48-0083) Connection: The chaining cable is used to interconnect two or more units when chained operation is desired. This cable is shown in Figure 7-10. To chain units:

1. The printer cable is connected to the RS232 connector on the first unit (as described in the preceding sub-section).
2. The 9-pin connector of the chaining cable is connected to the AUX connector on the unit.
3. The 25-pin connector of the chaining cable is connected to the RS232 connector of the next unit.
4. Steps 2 and 3 are repeated with additional chaining cables for each additional unit to be chained. Up to 15 units may be chained.

7.3.3 Chained Unit Addressing Command: After units are chained, units can be individually controlled by RS232 commands from one terminal, and units output their AUTO PRINT reports to that terminal. The addressing command must precede all other commands to the unit. The command is:

!u where "u" = A for the first unit and B, C, D, ...O for additional units.

The RS232 commands described in 7.1 can then follow this command.

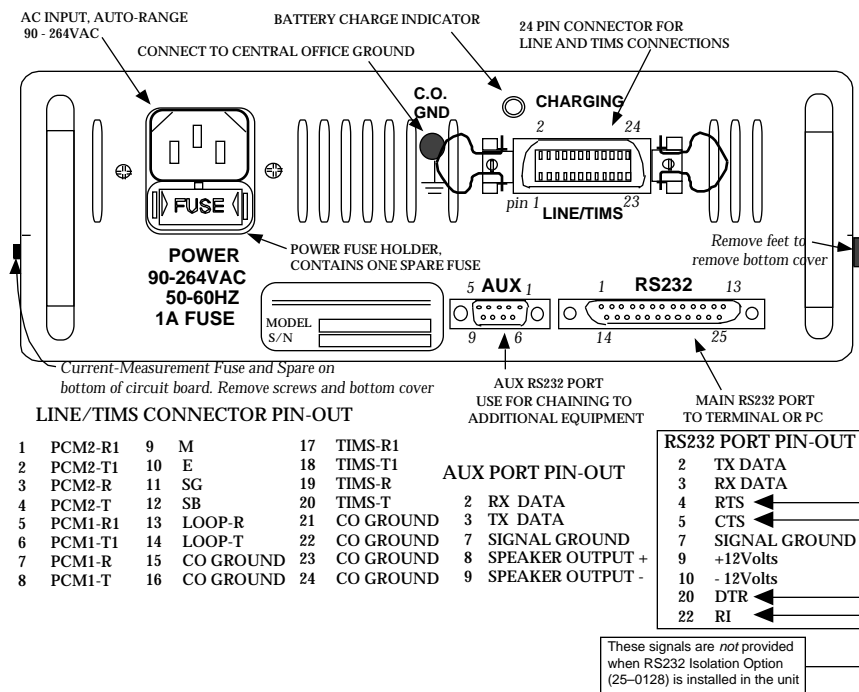

Figure 7-8. AM8a Rear Panel Connections

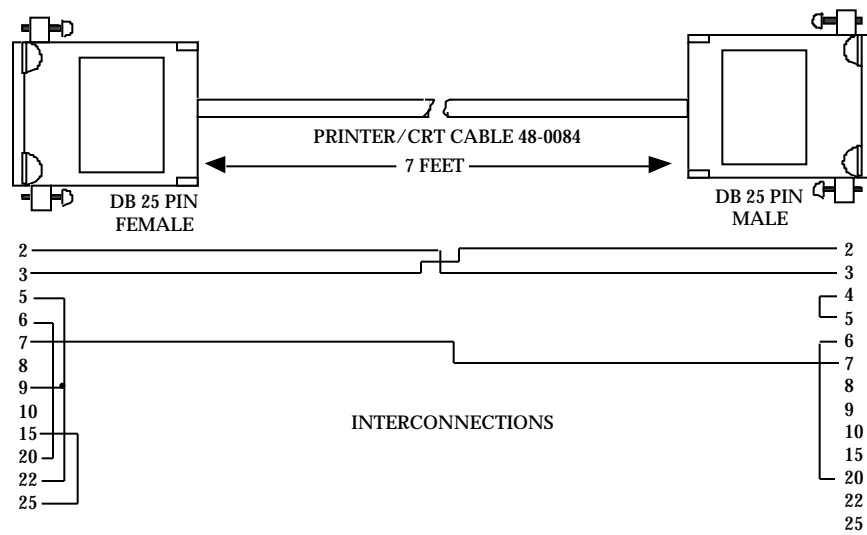

Figure 7-9. RS232 Printer Cable

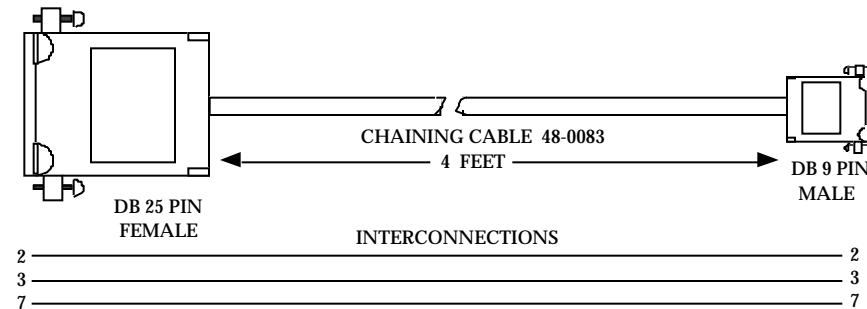

Figure 7-10. RS232 Chaining Cable

RS232 Entries and Printouts

(18-0037)

AM8a Instruction Manual

8. AM8a TECHNICAL SPECIFICATIONS

This Section consists of the specifications for the AM8a unit. It is in a Specification Sheet format (no sub-section numbers), and should be consulted for an overview of the unit's capabilities and for range of numerical parameters.

LINE INTERFACES

Analog Circuits (Switch or Terminal/Line)

- Loop Start
- Ground Start
- E & M 2 wire and 4 wire: Types I, II, III, IV, and V
- DID
- SF
- SS4 (optional)

Digital Circuits (PCM1 or PCM2)

- 1.544 megabits-per-second Pulse Code Modulation (PCM)
- Emulation and monitoring of all analog circuit types
- Two span (ports) provided to support drop-and-insert channel (Rpt. selections)
- Framing: D3/D4 , ESF, SLC@96 Modes 1 and 2 (SLC@96 is monitor-only)
- Zero Suppression: AMI, B8ZS, and ZCS

Dialing Modes

All circuit types support applicable dialing modes with full digit set,
1, 2, 3, 4, 5, 6, 7, 8, 9, 0, * (KP), # (ST), A, B, C, and (for DTMF only) D:

- Dial Pulse
 - Dual Tone Multi-Frequency (DTMF)
 - R1 Multi-Frequency (MF (R1))
 - Single Frequency (SF)

NOTE: MF(R1) digits will not be seen if DIALTONE is used as a Start Signal.

Start Signaling

All circuit types support applicable start signals:

- Immediate
- Delayed
- Wink
- Dial Tone

Line Signaling

Detect and generate all of these line signals:

- On Hook
- Off hook
- Wink
- Flash
- Unbalance (generate only)
- Ringing
- Ground Start (tip and ring)
- Answer supervision (reverse battery)

EMULATION

User-controlled parameters for circuit emulation. When shown as a range, parameters are selectable in unit steps, unless otherwise noted.

Digital Ports

Impedance: 100 Ω at 1.544 megabits-per-second bipolar PCM (switches to 1K Ω in DSX monitor mode)

Analog Office Battery

Voltage: 20 V to 72 V $\pm 2\%$
 Current: 120 mA maximum (not selectable)

Analog Loop

DC Loop Length: 0 to 2100 Ω , adjustable in 300 Ω steps
 DC Hold Resistance: 10 Ω , 330 Ω , 430 Ω
 AC Impedance: 135 Ω , 600 Ω , 900 Ω , 1200 Ω at 300 to 3300 Hz
 2.16 μF (IN or OUT). OUT= 24 μF
 Ringer Load: 2.0 type B ringer equivalents (2 REN)

Ringer Generation

Voltage: 30 Vrms to 105 Vrms $\pm 4\%$ in 5 Vrms steps
 Frequency: 15.0 Hz to 70.0 Hz in 0.1 Hz steps
 Load: 5.0 ringer equivalents (5 REN) maximum. (If no battery option and AC input is less than 100 Volts, unit will work with 3 REN or less. Loop Length must be 1500 ohms or more.)

Ring Trip: below 2100 ohms; 2100 ohm loop length will not detect ring trip (Loop Closure, answer).

Cadence:	
Rings:	1 to 3, individual on/off timers
On Time:	0 to 5000 ms
Off Time:	0 to 9999 ms
Ring time (before thermal shutdown)	
Minimum:	5 minutes (max load)
Typical:	10 minutes

Call Progress Tones

Dial Tone Generation:	
Low Frequency:	0, or 300 Hz to 3300 Hz
Low Frequency Level:	-40 dBm to -3 dBm
High Frequency:	0, or 300 Hz to 3300 Hz
High Frequency Level:	-40 dBm to -3 dBm
Cadence:	
Tone Burst:	1 to 3, individual on/off timers
On Time:	0 to 9999 ms
Off Time:	0 to 9999 ms

Start Signals

Wink	
Begin:	15 to 999 ms
Duration:	50 to 999 ms
Delay	
Begin:	15 to 999 ms
End:	100 to 9999 ms
Dial Tone Delay	
from Seizure:	15 to 9999 ms

Dialing

Pulse	
Speed:	5 to 25 pps
Percent Break:	40% to 85%
Interdigit Time:	120 to 999 ms±3ms
Accuracy at 10 pps:	±0.1 pps (40% to 75% break ±1%)
SF	
Frequency:	2600 Hz
Level:	-30dBm to 0 dBm
Speed:	8 to 16 pps
Percent Break:	40% to 85%
Interdigit Time:	120 to 999 ms ±2ms
Accuracy at 10 pps:	±0.1 pps (40% to 85% break ±1%)

DTMF

Low Band Frequencies:	697, 770, 852, 941 Hz
Low Band Offset:	-5% to +5%, in 0.1% steps
Low Band Level:	-40 dBm to -3 dBm
High Band Frequencies:	1209, 1336, 1477, 1633 Hz
High Band Offset:	-5% to +5%, in 0.1% steps
High Band Level:	-40 dBm to -3 dBm
On Time:	25 to 99 ms
Off Time:	25 to 99 ms

MF (R1)

NOTE: MF(R1) digits will not be seen if DIALTONE is used as a Start Signal.

Frequencies:	700, 900, 1100, 1300, 1500, 1700 Hz
Low Frequency Offset:	-5% to +5%, in 0.1% steps
Low Frequency Level:	-40 dBm to -3 dBm
High Frequency Offset:	-5% to +5%, in 0.1% steps
High Frequency Level:	-40 dBm to -3 dBm
On Time:	25 to 99 ms
Off Time:	25 to 99 ms

[KP digit ON time is twice programmed value.]

Tone Generation

Frequency:	300 Hz to 3300 Hz
Level:	-40 dBm to 0 dBm

Generation Accuracy for Emulation Parameters (Unless otherwise specified)

Frequency:	± 1 Hz
Level:	± 1dB
Timing:	± 1 ms

ANALYSIS

User-controlled threshold parameters for event detection. Ranges shown are selectable in unit steps unless noted.

Flash

Minimum On Hook Time:	50 to 1250 ms
-----------------------	---------------

Disconnect

Minimum On hook Time:	50 to 1250 ms
-----------------------	---------------

Call Progress Tones

First Frequency:	350, 440, 480, or 620 Hz
Second Frequency:	350, 440, 480, or 620 Hz
Frequency Tolerance:	0% to 3.5% in 0.1% steps
Minimum Level per Tone:	-30 dBm to -3 dBm
Allowable Twist:	-12 dBm to +12 dBm
Guard Time:	0 to 99 ms

Start Signals

Wink Begin:	15 to 999 ms
Wink Duration (min/max):	50 to 999 ms
Delay Begin (min/max):	0 to 999 ms
Delay End:	0 to 9999 ms
Dial Tone Delay from Seizure: (min/max):	0 to 9999 ms

Tone Dialing (DTMF and MF)

Frequency Tolerance:	0% to 3.5%, in 0.1% steps
Low Frequency Level Range:	-30 dBm to -3 dBm
High Frequency Level range:	-30 dBm to -3dBm
Allowable Twist:	-12 dBm to +12 dBm
DTMF Tone On/Off Duration:	25 to 99 ms \pm 2 ms
MF Tone On/Off Duration:	35 to 99 ms \pm 5 ms
Guard Time:	0 to 99 ms

Pulse Dialing

Speed Range:	5 to 25 pps
Percent Break:	40% to 85%
Accuracy at 10 pps:	\pm 0.2 pps (40% to 75% break, \pm 2%)
Interdigit Time:	200 to 999 ms \pm 5ms

SF Dialing

Speed Range:	8 to 13 pps
Percent break:	40% to 75%
Accuracy at 10 pps:	\pm 0.3 pps (40% to 75% break, \pm 2 ms)
Interdigit Time:	200 to 999 ms \pm 4 ms

Tone Threshold

Level Threshold:	-40 dBm to 0 dBm
------------------	------------------

On/Off Hook Threshold

Level Threshold: 2 to 60 V
 Accuracy: $\pm 3\% \pm 0.7V$

Measurement Accuracy of Analysis (Unless otherwise specified)

Frequency: ± 2 Hz (DTMF 25 ms; MF 35 ms)
 Level: ± 1 dB
 Timing: ± 2 ms

METER MEASUREMENTS

Analog AC Volts*

Range: 0 to 130Vrms $\pm 2\%$, $\pm 1Vrms^3$ ($\pm 0.7Vrms$ with $cm^{1,2}$ 0°C - 50°C) (DC offset < 75V, crest factor < 1.6) (15 to 75 Hz)

Loop/Ground Start: Tip-Ring¹, Tip-Ground², Ring-Ground², Common mode Tip-Ring²

E/M: Tip-Ring¹, Tip 1-Ring 1¹ (Emulation Range: 0 to 3Vrms), Common mode Tip-Ring², Common mode Tip 1-Ring 1², E-Ground², M-Ground², SG-Ground², SB-Ground²

PCM1/PCM2: Tx Common mode, Rx Common mode

Analog DC Volts*

Range: -150V to +150V $\pm 2\%$, $\pm 1V$ ($\pm 1V$ with $cm^{1,2}$ 0°C - 50°C)

Loop/Ground Start: Tip-Ring¹, Tip-Ground², Ring-Ground², Common mode Tip-Ring²

E/M: Tip-Ring¹, Tip 1-Ring 1¹ (Emulation Range : -4V to +4V) Common mode Tip-Ring², Common mode Tip 1-Ring 1², E-Ground², M-Ground², SG-Ground², SB-Ground²

PCM1/PCM2: Tx Common mode, Rx Common mode

Analog Tip Current*

DC Range: 5 to 120mA $\pm 2\%$, ± 1 mA (72Vdc MAX)
 Loop/Ground Start: Tip current¹

Noise (Analog or Selected PCM Channel)

Range: 50 to 90 dBrn ± 2 dBrn
 Filter: CMSG or Flat
 (Analog signals are also filtered 300 to 3300Hz flat by codec)
 Loop/Ground Start: Tip-Ring
 E & M: Tip-Ring, Tip 1-Ring 1
 PCM1/PCM2: Tx, Rx (selected channel)

Tone (Analog or Selected PCM Channel)

Range: -40 to $+2$ dBm ± 1 dBm (300 to 3300 Hz)
 Loop/Ground Start: Tip-Ring
 E & M: Tip-Ring, Tip 1-Ring 1
 PCM1/PCM2: Tx, Rx (selected channel)

NOTE: *Protection circuits assume a source impedance >300 to limit current.

NOTE: DO NOT MEASURE LOW SOURCE IMPEDANCE VOLTAGES. Protection circuits will be damaged.

NOTE: ¹Common mode AC plus DC voltage < 100 V peak.

NOTE: ²Common mode AC plus DC voltage < 10 V peak.

NOTE: ³Event details display of ringing is 0 to 130Vrms $\pm 3\%$, ± 1 Vrms(± 0.7 Vrms w/cm1,2 0°C - 50°C).

Analog Bipolar Amplitude on PCM1/PCM2⁴

Range: -16 to $+3$ dBdsx ± 1 dBdsx (Rx only)
 Types: Emulation (Line), DSX monitor

NOTE: ⁴Measurements are displayed as peak voltage at the DSX point. VdBdsx = $20 \log(V_{\text{peak}}/3)$

PCM1 and PCM2 (T1 and SLC®96) METER MEASUREMENTS

Measurements are derived from the decoding of the PCM bit-stream.

Transmission Errors

BPV:	Bipolar Violations: displayed count for every 64 BPV (64, 128, ...)
FERR:	Frame errors: displayed count for every 4 FERR (4, 8, ...)
CRC:	Cyclic Redundancy Check: Calculated for ESF framing mode
SLIPS:	Counts insertion or deletion of data bits in data stream.
ALARMS:	Counts YELLOW and BLUE alarms. Indicates "yes" or "no" occurrence of YELLOW and BLUE alarms.

Frame Synchronization

TX, RX:	Shows phase relationship on dual bar graphs
---------	---

Signaling Bits

TX, RX	Shows a and b signaling bits for each of 24 TX and RX channels
--------	--

Channel Noise and Tone Measurements

TX, RX	Noise and Tone measurements on each of 24 channels; see "Noise (Analog or Selected PCM Channel)" and "Tone (Analog or Selected PCM Channel)" on previous page.
--------	--

SLC®96 Alarm Conditions

TX, RX	Display of "flags" for A through D shelf/ lines, and power
--------	--

SLC®96 Protection Status

TX, RX	4-bit display which "decodes" to indicate status
--------	--

SLC®96 Maintenance Message

TX, RX	Display of "flags" to indicate presence or absence of messages and indicates Channel Number and Time Slot.
--------	--

TRANSMISSION IMPAIRMENT MEASUREMENT

Direct and Reversed Connections are provided for connection of an AM5XT or similar Transmission Impairment Measurement Set (TIMS) to TX/2W and RX circuits.

GENERAL

Size:	8.3"W 3.5"H 12.1"D
Weight:	6.5 lb, 11.5 lb with battery option
Shipping Weight:	10 lb, 15 lb with battery option
Operating Temperature:	0°C to 50°C
Humidity:	10 to 90% non-condensing
Power Requirements:	90Vac to 264Vac, 50 to 60 Hz, 45 Watts (Ring load capacity reduced to 3 REN at 100 Vac)

OPTIONS

RS232c:	Up to 9600 baud, selectable parity (EVEN or ODD with character length of 7 bits + 1 stop bit; or NO parity with character length of 8 bits + 1 stop bit)
Printing:	Set-ups, Events, Meters
Battery:	Sealed lead-acid battery and charger. Provides up to 8 hours of portable use before recharge. Recharges in 8 hours or less at 25°C.

ACCESSORIES

- External Handset
- Soft Case
- Rack Mounting Kit
- Printer

Technical Specifications

(18-0037)

AM8a Instruction Manual

9. WARRANTY, SERVICE, AND CALIBRATION

9.1 WARRANTY

AMERITEC Corporation warrants that its electronic instrument products are manufactured to the highest commercial standards and are free from any defects in material or workmanship.

For a period of one (1) year from shipment, AMERITEC will repair, without charge to the original purchaser, any unit which upon inspection by AMERITEC proves to be defective.

This warranty is the sole warranty offered by AMERITEC and is in lieu of all other obligations or liabilities, including claims of consequential damage; however, an **EXTENDED WARRANTY PLAN** may be purchased. For information contact an Ameritec Sales Representative.

9.2 SERVICE POLICY

AMERITEC products are designed with plug-in printed circuit boards and modular assemblies. Once a problem is localized, service is accomplished by PC board (or module) replacement.

9.3 CALIBRATION POLICY

All AMERITEC products are manufactured to commercial standards and are calibrated with equipment traceable to NIST (National Institute of Standards and Technology). With the exception of component failures or abuse, AMERITEC instruments are designed to maintain compliance with their published specifications throughout their service life.

While periodic calibration verification is normally not required, in critical applications it is recommended that verification be accomplished annually.

Calibration verification is most efficiently accomplished by return of the equipment to the AMERITEC factory where specialized test equipment is used. Field calibration verification is not supported by AMERITEC.

9.4 RETURN OF UNIT

In the event of a malfunction, call or write to the AMERITEC factory and obtain a return authorization number. Return the unit to AMERITEC freight prepaid with a note (in-warranty repair) or a purchase order for the repair (out-of-warranty repair) listing the following information:

- Return authorization number from AMERITEC.
- Return shipment address of purchaser.
- Name and telephone number of person at purchaser's location familiar with the problem.
- Brief description of problem (include any printouts that may have a bearing on the problem, if possible).
- Terms of payment for repair costs (out-of-warranty unit).

The unit will be repaired and returned freight-prepaid for units in warranty and freight-collect for units out-of-warranty. As stated above, a Purchase Order to cover the cost of repair must accompany any out-of-warranty return of the unit to AMERITEC.

Ameritec

760 Arrow Grand Circle
Covina, CA 91722 USA

TEL 626.915.5441

FAX 626.915.7181

www.ameritec.com

A. METER DISPLAY

This Appendix describes the PCM operations, connections, and other supplementary information for tests on T1 and SLC[®]96 circuits.

A.1 PCM Operations and Data Flow

The PCM operations of the AM8a are controlled by choices in the menus. (Refer to Figures A-1 through A-4 for an illustration of signal paths and processing within the AM8a.). For external connections to user's equipment refer to Figure A-5 for monitor, and Figure A-6 for emulate, or drop and insert (rpt 1 to 2 or rpt 2 to 1). The list of choices follows (" \langle " indicates default selection).

A.1.1 MODE CONFIG Menu Settings

The IMITATE parameter will be set to:

- 0 –te/line: AM8a is emulating/monitoring Terminal Equipment. Flashing events on display are from connected equipment.
- 1 –<switch>: AM8a is emulating/monitoring Switching Equipment. Flashing events on display are from AM8a itself.

The MODE parameter will be set to:

- 0 –emulate: In accordance with IMITATE parameter setting, the AM8a sends, receives, and displays appropriate signals. Unit responds to incoming signals by returning an appropriate signal.

CAUTION: Connections to RX and TX lines must be made in the correct order when in "rpt 1 to 2" or "rpt 2 to 1" (drop and insert) to avoid "hits" which would cause PCM alarms. Refer to Figure A-6.

- 1 –<monitor>: AM8a will analyze RX or TX data and is bridged to the RX and TX path via the user's MONITOR jacks. The IMITATE parameter will usually be set to the end of equipment being monitored (Figure A-1 and A-5). The AM8a must be in monitor when it is connected to SLC[®]96 lines.

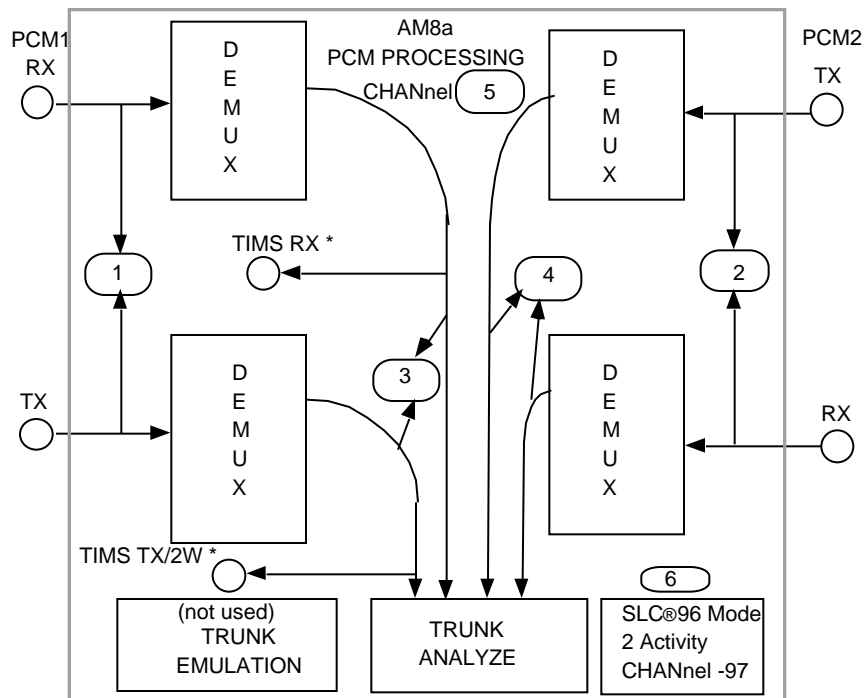

* TIMS TX/2W and RX jack functions apply to selected pcm1 (shown) or pcm2. TX and RX Functions can be reversed by TIMS key selection.

- 1 METER PCM 1 } RX dBdsx; BPV, FERR, CRC, SLIPS, YELLOW, BLUE;
TX-RX FRAME SYNC; TX-RX A B bits;
- 2 METER PCM 2 } SLC@96 TX-RX ALARM, PROTECTION, MAINTENANCE
- 3 METER PCM1 RX or TX CHANNEL Tone or Noise
- 4 METER PCM2 RX or TX CHANNEL Tone or Noise
- 5 T1: 1 through 24, or 0 (first off-hook channel).
SLC@96 Mode 1 and Mode 2: -1 through -96 Voice Channels
- 6 Mode 2: -97 (4 KBs Data Channel)

Figure A-1. Monitor PCM Processing Diagram

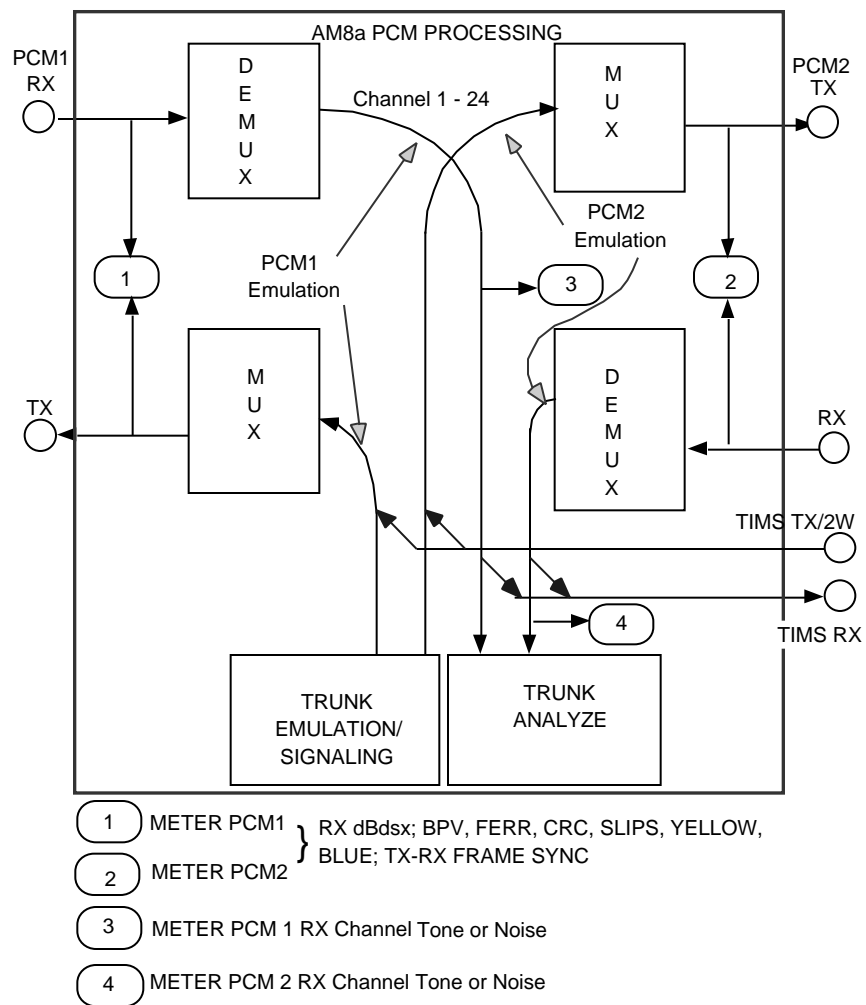
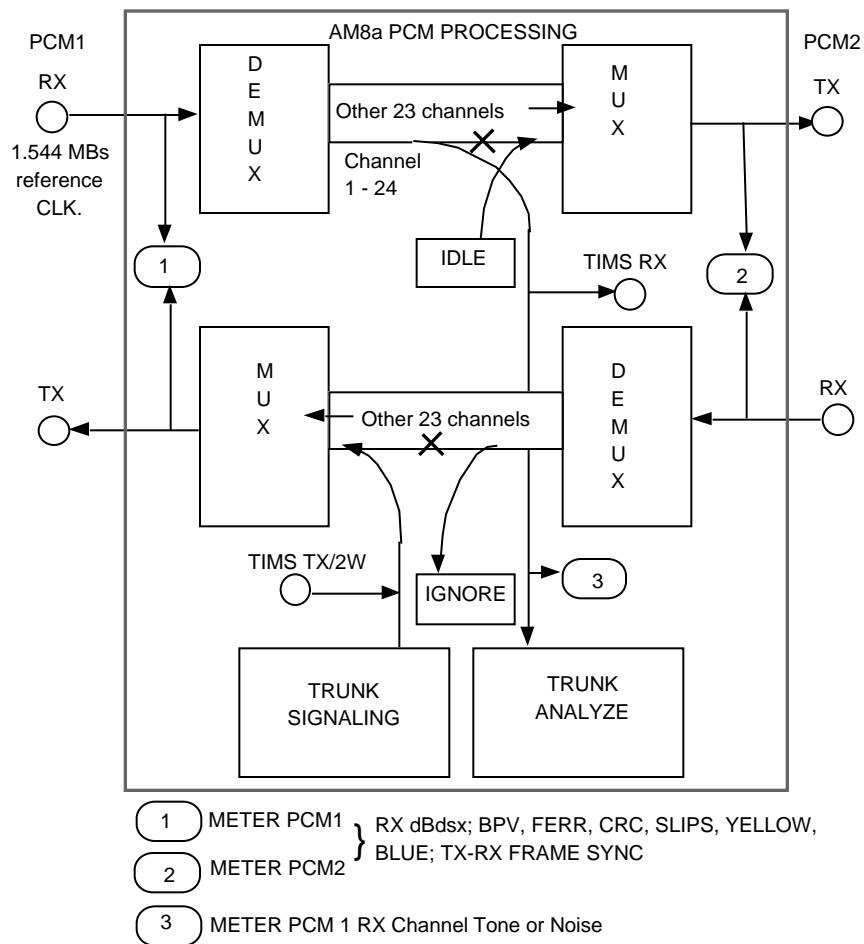
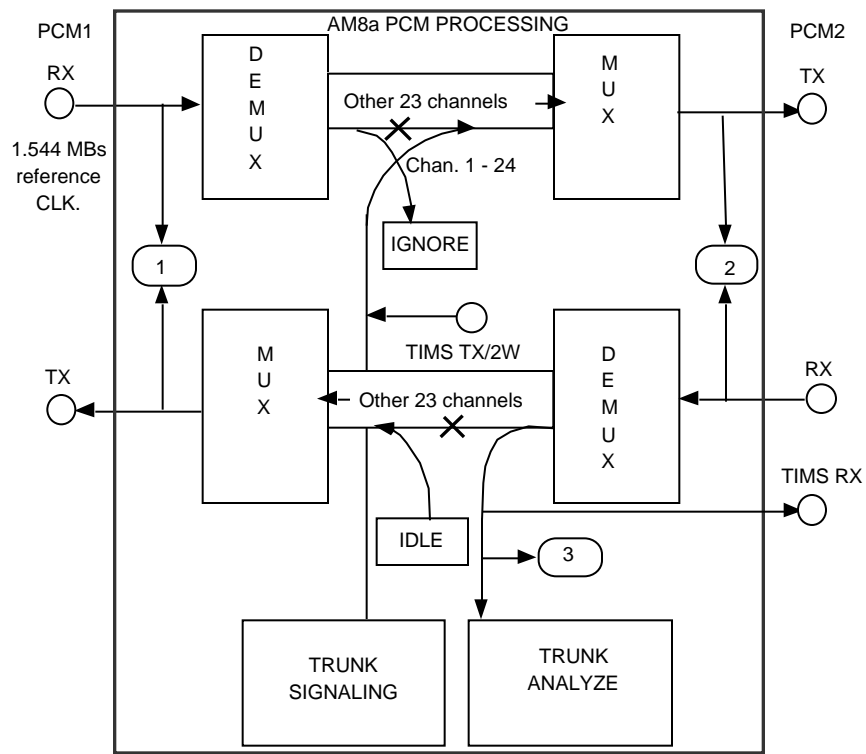

Figure A-2. Emulate PCM Processing Diagram



Note: All channels passed from RX to TX in MODE: monitor.

Figure A-3. Rpt (Repeat) 1 to 2 PCM Processing Diagram



- 1 METER PCM1 } RX dBdsx; BPV, FERR, CRC, SLIPS, YELLOW,
- 2 METER PCM2 } BLUE; TX-RX FRAME SYNC
- 3 METER PCM 2 RX Channel Tone or Noise

Note: All channels passed from RX to TX in MODE: monitor.

Figure A-4. Rpt (Repeat) 2 to 1 PCM Processing Diagram

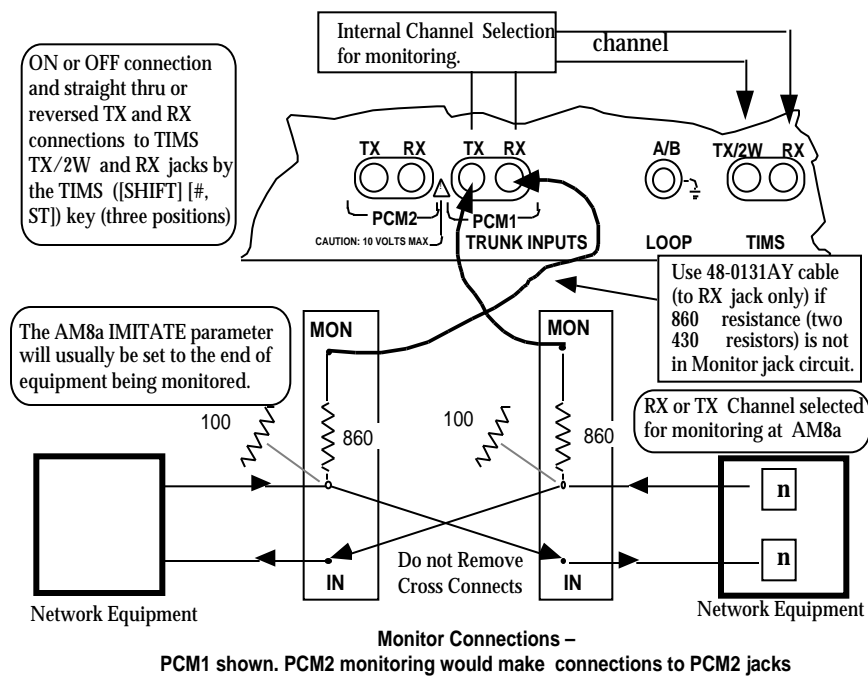

Figure A-5. Monitor PCM Connection Points

A.1.2 CIRCUIT CONFIG Menu Settings

The ANALOG/PCM parameter will be set to:

- 1 –pcm int. clk: 1.544 Mbps clocking will originate with the AM8a from the TX jack to the equipment under test (Figure A-5).
- 2 –<pcm loop clk>: clocking from the equipment under test will control the AM8a clocking via the RX jack.

NOTE: With either "rpt 1 to 2" or "rpt2 to 1" drop and insert tests, the signal with the clocking data must come into the PCM1 RX jack. Also refer to CAUTION concerning order of jack connections.

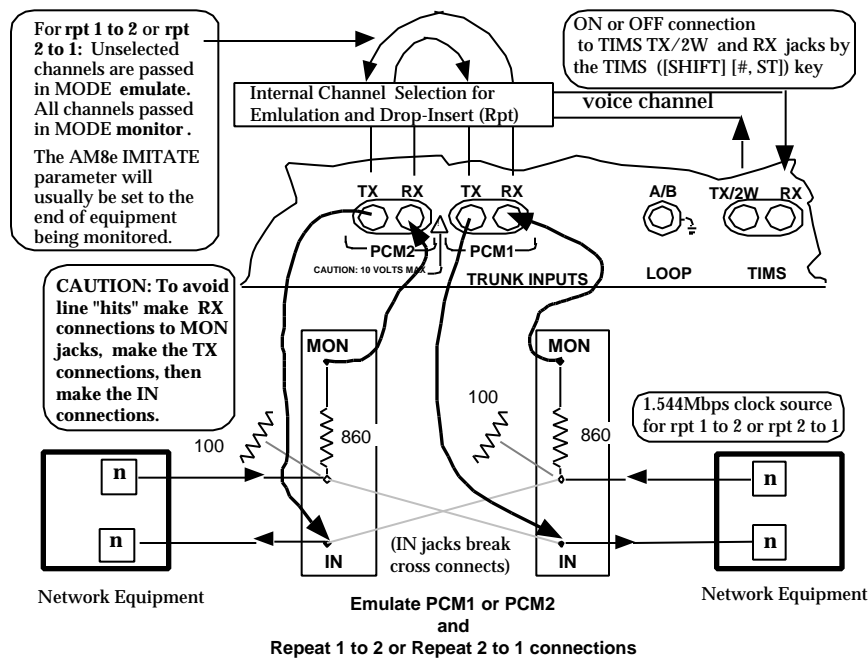

Figure A-6. Emulate and Repeat (Drop and Insert) PCM Connections

A.1.3 PCM CONFIG 1 and CONFIG 2 Menu Settings

The INPUT parameter will be set to:

- 0 –<pcm 1 on>: circuitry of AM8a is connected to the PCM1 RX and TX jacks (Figures A-1, A-2, and A-6).
- 1 –pcm2 on: circuitry of AM8a is connected to the PCM2 RX and TX jacks (Figures A-1, A-2, and A-6).
- 2 –rpt1 to 2: circuitry of AM8a is connected to provide a path from PCM1 to PCM2 jacks (RX to TX) in both directions. In emulate mode, a single T1 voice channel may be dropped from the other 24 channels for tests. For the selected channel (see Figures A-3 and A-6):
 - TX path toward PCM2 is idled; RX path from PCM2 is ignored.
 - TX path toward PCM1 is emulated; RX path from PCM 1 is analyzed.

- 3 –rpt2 to 1: circuitry of AM8a is connected to provide a path from PCM1 to PCM2 jacks (RX to TX) in both directions. In emulate mode, a single T1 voice channel may be dropped from the other 24 channels for tests. For the selected channel (see Figures A-3 and A-6):
 - TX path toward PCM1 is idled; RX path from PCM1 is ignored.
 - TX path toward PCM2 is emulated; RX path from PCM 2 is analyzed.
 - FRAMING parameter is set to D3/D4 or ESF for T1 lines. It is set to SLC®96 I or SLC®96 II if SLC®96 lines are being monitored.

CAUTION: When FRAMING is set for SLC®96 circuits, the E & M/SLC® LED indicator will be flashing. AM8a must also be in MODE monitor and INPUT pcm1 or pcm2 for tests of SLC®96 circuits.

The ZERO SUP parameter is set to AM1, B8ZS, or ZCS to match the equipment under test.

The CHANnel parameter:

- **For T1 lines:** the parameter must be set to 1 through 24. This setting determines which time-slot/voice channel will be accessed for emulation (emulation and analysis), monitoring (analysis only), or repeat (emulation and analysis on one channel while leaving other channels uninterrupted.).
- **For monitor of any lines (or "spans"):** the parameter may be set to 0. This will cause the unit to automatically monitor whichever time-slot first goes active.
- **For SLC®96 I monitor:** the parameter may be set to time-slot 1 to 24 or voice channel –1 to –96. The user must select a channel appropriate to the span:
A = –1 to –24, B = –25 to –48, C = –49 to –72, and D = –73 to –96
(Refer to Table 6-5 for the fixed voice channel to time-slot assignments).
- **For SLC®96 II monitor:** the parameter may be set to -1 to -96 to monitor a channel. In SLC®96 Mode II, 96 lines are allocated as time-slots become available, but the user must still select an appropriate channel for the span being input to the AM8a:

A = –1 to –48, C = –49 to –96

NOTE: On Span C, 1 to 48 decoded from Activity Message = -49 to -96 in CHANnel parameter (refer to 2.5.4).

- **For SLC®96 II monitor:** the parameter may be set to -97 to monitor a 4 KBps data link Activity Message (unit must be connected to span A). This message provides information on channel activity by "Line Groups". (refer to 2.5.4).
- **OFF HK a/b and ON HK a/b:** These parameters must be set to match the equipment that is being tested. Normally, the auto setting is used.

A.1.4 TRUNK CONFIG Menu Settings

TRUNK TYPE: The default setting is for E & M 4W. Other options may be selected, as needed, to accommodate the type of analog equipment that is connected within the DSX at the T1 or SLC® 96 shelves.

SLC® TYPE: Takes effect if TRUNK TYPE is set to loop start, ground start or DID.

A.1.5 DISPLAY CONFIG Menu Settings

SLC® MSG: This parameter is a series of flags which turn on the Concentrator Field message detection for SLC®96 II. These messages (refer to 2.5.3) are obtained by monitoring the 4kBps data channel (CHANnel -97) on span A. If the a or b message flags are turned on, activity messages provide information on the channels which are active (refer to 2.5.4).

A.1.6 EMULATE Menu Settings

Those parameters that are appropriate to PCM must be set properly for the user's requirements. Refer to Section 7, Table 7-15 (column headed "pcm") for identification of those parameters which apply.

A.1.7 ANALYZE Menus

Those parameters that are appropriate to the EMULATE menu selections may be set to the user's requirements.

A.2 PCM Connection Diagrams

Figures A-5 and A-6 illustrate typical connections between a user's equipment and the AM8a.

A.2.1 Monitoring Connections

Figure A-5 shows the recommended monitoring connections through series resistors at the user's monitor jacks. If series resistors are not provided by the user, 48-0131AY cables must be used; this cable provides the necessary series resistance. The AM8a will have no effect on the signal exchange when monitoring a circuit.

A.2.2 ANALYZE Menus

Figure A-6 shows both emulate and "drop and insert" connections. In emulate, the unit substitutes for the "near-end" that normally would be connected via the jumpers shown removed in the diagram. In some installations, the user's RX and TX jacks may have contacts that break the cross connections when the test cables are plugged in.

In rpt 1 to 2 or rpt 2 to 1 (drop and insert), the unit provides the path for all but one T1 channel (selected by PCM CONFIG, CHANnel 1 through 24). In monitor, all signals pass through the AM8a.

CAUTION: Connect the cables from the AM8a RX jacks and TX jacks to the DSX jacks in the proper order to avoid "hits" that can result in alarm messages from the network equipment.

INDEX

#

2.16uf.....3-1

A

Accessories8-9

Alarm TX or RX.....6-17

All Calls, Events & Details 2-11, 7-17

All Calls, Events Only..... 2-11, 7-16

AM8a Configuration2-12

AM8a Events Display..... 1-4

AM8a Front Panel 1-1

AM8a Rear Panel Connections7-24

AM8a Technical Specifications.....8-1

AMI2-4

Analog2-2

Analog AC Volts8-6

Analog Bipolar Amplitude on PCM1/PCM28-7

Analog Circuits.....8-1

Analog DC Volts8-6

Analog Impedance.....2-2

Analog Loop.....8-2

Analog Office Battery8-2

Analog Tip Current.....8-7

Analog/PCM.....2-2

Analysis8-4

Analysis Parameters4-1

ANALYZE ([SHIFT][7]) Key 1-8

Analyze Menus.....A-9, A-10

Appendix A: Meter Display A-1

Arrow Keys	1-2
Audio Monitoring	1-17
Auto Dial Setup Commands	7-3
AUTO ([SHIFT][VALUE [^]]) Key	1-10
Auto and Manual Dialing	5-1
AUTO DIAL ([SHIFT][8]) Key	1-8

B

B8ZS	2-4
Baud Rate	2-9
BLANK ([SHIFT][SHIFT][7]) Key	1-13
Blue	6-14
BPV	6-13
Break %	3-2, 4-4

C

Cables for AM8a Front Panel Test/Meter Connections	6-3
Calibration Policy	9-1
Call Initiate (Signaling) Commands	7-4
Call Progress Tones	8-3, 8-5
CANCEL ([SHIFT][D]) Key	1-11
Chained Unit Addressing Command	7-23
Chaining Cable (48-0083) Connection	7-22
Chan	2-5
Change Parameter	7-3
Channel Noise and Tone Measurements	8-8
Circuit Configuration	2-2
Circuit Configuration Menu Settings	A-6
Clock Configuration	2-12
CONFIG'N ([SHIFT][5]) Key	1-8

Configuration Parameters	2-1
Control ON/OFF Keys	1-9
CR Delay sec	2-10
CRC	6-14

D

D3/D4	2-4
Data Entry Functions	1-1
Data Entry Keys for Signaling	1-13
DC Hold.....	3-2
Delay: Begin/End ms.....	3-7
Delay Start Analyze.....	4-3
Dial Tone Emulate 1.....	3-4
Dial Tone Emulate 2.....	3-4
Dialed Digits.....	1-7
Dialing	8-3
Dialing Emulate.....	3-2
Dialing Modes	8-1
Dialtone Start Analyze: Dialtone RCVD ms (min/max).....	4-2
Dialtone/	4-2
Dialtone/Delay.....	4-2
Dialtone/Wink	4-2
DID	2-6
Digit Detection	2-8
Digital Circuits	8-1
Digital Ports.....	8-2
Disconnect	8-4
Disconnect ms (min).....	4-1
Display Configuration 1 and Configuration 2	2-7
Display Configuration Menu Settings	A-9
Display Menu	7-3
DL SND ms	3-5

DTMF Frequencies.....	4-6
DTMF/MF Analyze 1.....	4-5
DTMF/MF Analyze 2.....	4-5
DTMF/MF Analyze 3.....	4-8
DTMF/MF Emulate 1.....	3-3
DTMF/MF Emulate 2.....	3-3
DUR ms (min/max).....	4-3

E

E & M 2W.....	2-6
E & M 4W.....	2-6
E & M and SF – Analog Measure.....	6-9, 6-11
E & M and SF Test/Meter Front Panel Connections.....	6-5
E & M Type.....	2-6
Emulate.....	2-1
EMULATE ([SHIFT][6]) Key.....	1-8
Emulate and Repeat (Drop and Insert) PCM Connections.....	A-7
Emulate Menu Settings.....	A-9
Emulate Parameters.....	3-1
Emulate PCM Processing Diagram.....	A-3
Emulation.....	8-2
End ms (min).....	4-3
ESF.....	2-4
Event-only Printout.....	7-16
Events ([SHIFT][1]) Key.....	1-3
Events and Details Printout (Emulate Mode).....	7-18
Events and Details Printout (Monitor Mode).....	7-17
Events and Meter Keys and Display.....	1-3
Events Display Character Set.....	1-4
Events Display Commands.....	7-4

F

FERR	6-14
Flash	8-4
FLASH ([SHIFT][SHIFT][4]) Key	1-13
Flash ms (min)	4-1
Flawed Calls, Events & Details	2-11, 7-17
Flawed Calls, Events Only	2-11, 7-17
Frame Synchronization	8-8
Framing	2-4
FREEZE ([SHIFT][B]) Key	1-10
Frequency % (max)	4-6
Frequency + %hz	3-7
Frequency hz	3-4, 3-6
Front Panel Operation	1-1
Front Panel Programming Methods	1-1

G

General	8-9
Generation Accuracy for Emulation Parameters	8-4
Ground	2-6
Guard ms	4-8

H

Handset	1-17
HI Band dB	4-5
HI:dBm/hz%	3-3
Hook Analyze	4-1
Hook Flash ms	3-5

I

Imitate.....	2-1
Input.....	2-3
INPUT ([SHIFT][*, KP]) Key	1-9
Interdigit ms.....	3-2
Interdigit ms (min).....	4-4
It(mA) dc	6-7

L

Length.....	3-1
Level.....	3-7
Level dBm	3-4
Limit	2-8
Line Interfaces	8-1
Line Signaling	8-2
Line Unbal ms	3-5
LO Band dB (min/max).....	4-5
LO:dBm/hz%	3-3
Long Print.....	1-11
Loop.....	2-6
Loop Emulate	3-1
Loop Start, Ground Start, DID – Analog Measure.....	6-7
Loop Type	3-2
Loop/Ground Start and DID Analog Test/Meter Front Panel Connections	6-4

M

Maintenance TX or RX.....	6-18
Manual Dialing	5-2
Manual Long Print.....	7-19
Manual Long Print (Meter Display Example).....	7-20
Manual Long Print (Setup Example).....	7-21

Manual Reset	2-7
Manual Short Print	7-18
Manual Short Print (Meter Display Example).....	7-18
Manual Short Print (Emulate Analog Switch, Te, PCM Examples)	7-19
Measure Display (Making Measurements).....	6-1
Measure/Scale Menu	6-1
Measurement Accuracy of Analysis.....	8-6
Menu/Data Control Keys.....	1-10
Meter ([SHIFT][2]) Key.....	1-7
Meter Display	6-1
Meter Display Commands	7-4
Meter Measurements	8-6
Meter Selections and Connections	6-2
MF(R1) Frequencies.....	4-7
Mode.....	2-1, 2-7
Mode Configuration	2-1
Mode Configuration Menu Settings	A-1
Monitor	2-1
Monitor PCM Connection Points	A-6
Monitor PCM Processing Diagram	A-2
Monitoring Connections.....	A-10
N	
Narrow	2-8
New Call Reset	2-7
No-Shift Functions	1-1
Noise (Analog or Selected PCM Channel).....	8-7
Noise Measure	6-12

O

Off.....	2-11, 7-16
Off Hook a/b or On Hook a/b.....	2-5
Off Hook vdc (min).....	4-9
On/Off Hook Threshold.....	8-6
On/Off ms.....	3-3, 3-6
On-Off (Control Toggle) Commands.....	7-4
Options.....	8-9
Out.....	3-1

P

Parity.....	2-10
Password.....	2-10
PCM Configuration 1 and Configuration 2 Menu Settings.....	A-7
PCM Configuration 1 and PCM Configuration 2.....	2-3
PCM Connection Diagrams.....	A-10
PCM INT CLK.....	2-2
PCM LOOP CLK.....	2-2
PCM Operations and Data Flow.....	A-1
PCM T1/SLC@96 Test/Meter Front Panel Connections.....	6-6
PCM1 On.....	2-3
PCM1 and PCM2 Bipolar Violation (Count and Status) Measure.....	6-13
PCM1 and PCM2 (T1 and SLC@96) Meter Measurements.....	8-8
PCM1 and PCM2 TX or RX A/B Measure.....	6-15
PCM1 or PCM2 Frame Sync Measure.....	6-14
PCM2 On.....	2-3
PRINT ([SHIFT][C]) Key.....	1-11
Print Configuration.....	2-11
Print Menu.....	7-3
Printer Cable (48-0084) Connection.....	7-22
Printer Commands.....	7-2

Printouts.....	7-16
Procedure to Set Off Hook vdc (min) Threshold	4-9
Protection TX or RX	6-18
Pulse Analyze 1	4-4
Pulse Analyze 2	4-4
Pulse Dialing	8-5
Pulse Emulate	3-2

R

Recall Auto Dial Sequence.....	1-16
Recall Emulate.....	3-5
Recall Setup Parameters	1-16
Recall Setups	1-16
Return of Unit.....	9-2
REV Key	1-12
RING Key.....	1-12
Ringer Generation	8-2
Ringing Emulate 1	3-6
Ringing Emulate 2.....	3-6
Repeat 1 to 2 PCM Processing Diagram	A-4
Repeat 2 to 2 PCM Processing Diagram	A-5
RPT 1 to 2.....	2-3
RPT 2 to 1.....	2-4
RS232 Analyze Menu Commands	7-10
RS232 Auto Dial Setup Commands.....	7-12
RS232 Call Initiate (Signaling) Commands.....	7-13
RS232 Chaining Cable	7-25
RS232 Command Description	7-1
RS232 Configuration	2-9
RS232 Configuration Menu Commands	7-6
RS232 Emulate Menu Commands	7-9
RS232 Entries and Printouts.....	7-1

RS232 Events Display Commands.....	7-14
RS232 Meter Display Commands (Analog Voltage Measurements).....	7-14
RS232 Meter Display Commands (Meter Selections)	7-14
RS232 Meter Display Commands (Noise Measurements).....	7-16
RS232 Meter Display Commands (PCM Measurements).....	7-15
RS232 On-Off (Control Toggle) Commands	7-13
RS232 Printer Cable	7-25
RS232 Printing Commands	7-5
RS232 Rear-Panel Connections	7-22
RS232 Terminal Commands	7-4
RX1 dBdsx or RX2 dBdsx	6-12
RX1 dBdsx or RX2 dBdsx in Emulation Mode	6-12
RX1 dBdsx or RX2 dBdsx in Monitor Mode.....	6-12
RX1 Tone or RX2 Tone	6-12
RX1 Vcm or RX2 Vcm, dc or ac	6-11

S

Scroll.....	2-7
Security Configuration	2-10
SEIZE Key.....	1-11
Select and Use Autodial Sequence	5-2
SEND TONE ([SHIFT][RING]) Key	1-12
Send Tone Emulate.....	3-4
Service Policy	9-1
Setup Area	1-8
Setup Menu Commands for Config, Emulate, and Analyze	7-2
Setup Protect.....	2-10
SF.....	2-6
SF Dialing.....	8-5
SF Emulate	3-7
Shift Key.....	1-1
Short Print.....	1-11

Signaling Bits	8-8
Signaling Keys.....	1-11
Signaling Status LEDs.....	1-14
Single Party	2-6
SLC® Activity Message.....	2-9
SLC® Message.....	2-8
SLC® Type.....	2-6
SLC®96 I	2-4
SLC®96 II.....	2-4
SLC®96 II Concentrator Field Messages	6-19
SLC®96 Alarm Conditions	8-8
SLC®96 Alarm Conditions Meter Display	6-17, 6-18
SLC®96 Maintenance Message	8-8
SLC®96 Mode I Channel Number to Time Slot Assignments	6-16
SLC®96 Mode I or II Messages.....	6-17
SLC®96 Mode I Time-Slot to Voice Channel Assignment.....	6-15
SLC®96 Mode II Time-Slot to Voice Channel Assignment	6-15
SLC®96 Protection Status.....	8-8
Slips	6-14
Speakerphone in Talk Mode.....	1-16
Speakerphone/Audio Monitor	1-16
Special Auto-Dial Functions	5-2
Speed pps.....	3-2
Speed pps (min/max).....	4-4
Start BGN ms (min/max).....	4-3
START Key.....	1-12
Start Signal	3-2, 8-3, 8-5
Start Signal Analyze: Expected Type.....	4-2
Start Signaling	8-1

Start Time Emulate.....	3-7
Status Blue.....	6-14
Status Yellow.....	6-14
Store Autodial Sequence	5-1
Store Setup.....	1-15
Switch.....	2-1

T

T/t Mask (single-tone event selection)	2-9
T1 Time-Slot to Voice Channel Assignment	6-15
T1:dBm/hz.....	3-5
T2:dBm/hz.....	3-5
TALK ([SHIFT][\downarrow VALUE]) Key	1-10
Te/line.....	2-1
Terminal Commands	7-2
Termination Emulate	3-1
Threshold Analyze.....	4-8
TIMS ([SHIFT][#, ST]) Key	1-9
TOGGLE DIAL ([SHIFT][SHIFT][6]) Key	1-13
Tone.....	6-8
Tone (Analog or Selected PCM Channel).....	8-7
Tone dB (min)	4-8
Tone Dialing (DTMF and MF).....	8-5
Tone Generation	8-4
Tone On/Off ms (min).....	4-8
Tone Threshold.....	8-5
Transmission Errors.....	8-8
Transmission Impairment Measurement	8-9
Trunk Configuration	2-5
Trunk Configuration Menu Settings.....	A-9
Trunk Type	2-6
Twist dB (min/max)	4-6

TX Tone or RX Tone	6-10
TX Vcm or RX Vcm, dc or ac.....	6-9
TX Vt-r or RX Vt-r, dc or ac.....	6-9
TX1 Tone or TX2 Tone.....	6-11
TX1 Vcm or TX2 Vcm, dc or ac.....	6-11

U

UNBALANCE ([SHIFT][SHIFT][5]) Key.....	1-13
Universal Voice Grade	2-6

V

V cm dc or ac.....	6-7
V r-g dc or ac.....	6-7
V t-g dc or ac.....	6-7
V t-r dc or ac.....	6-7
Ve or Vm, dc or ac	6-9
Voltage	3-1
Voltage vrms	3-6
Vsb or Vsg, dc or ac.....	6-10

W

WAIT ([SHIFT][SHIFT][3]) Key.....	1-13
WAIT DT ([SHIFT][SHIFT][1]) Key.....	1-13
WAIT WINK ([SHIFT][SHIFT][2]) Key.....	1-13
Warranty	9-1
Warranty, Service, and Calibration	9-1
Wide	2-8
Wink: Begin/DUR ms	3-7
Wink BGN ms (min)	4-3
Wink Start.....	4-3

Y

Yellow6-14

Z

ZCS2-5

Zero Sup2-4



Ameritec is dedicated to serving the worldwide telecommunications community by providing competitively priced, state-of-the-art test equipment that is supported by the finest in marketing, engineering development and customer service.

Ameritec

760 Arrow Grand Circle
Covina, CA 91722 USA
TEL 626.915.5441
FAX 626.915.7181
www.ameritec.com